

# **MENLO COMMONS HOMEOWNERS ASSOCIATION**

**THIS PACKET CONTAINS:**

**RESTATED ARTICLES OF INCORPORATION**

**AMENDED AND RESTATED DECLARATION (CC&R's)**

**AMENDED BYLAWS**

**FIRST AMENDMENT TO AMENDED AND RESTATED DECLARATION**

# AGENCIJA ZA VEŠTAČENJE I PROJEKTOVANJE IZ OBLASTI GRAĐEVINARSTVA I PROMETA NEKRETNIM PRAVIMA

IZ OBLASTI GRAĐEVINARSTVA I PROMETA NEKRETNIM PRAVIMA

POSREDOVANJE U PROMETU NEKRETNIM PRAVIMA I PROMET NEKRETNIM PRAVIMA

(POSREDOVANJE U PROMETU NEKRETNIM PRAVIMA I PROMET NEKRETNIM PRAVIMA)

POSREDOVANJE U PROMETU NEKRETNIM PRAVIMA

POSREDOVANJE U PROMETU NEKRETNIM PRAVIMA I PROMET NEKRETNIM PRAVIMA

RESTATED

ARTICLES OF INCORPORATION

OF



THE MENLO COMMONS HOMEOWNERS ASSOCIATION

\_\_\_Helen Olson\_\_\_ and \_\_\_Kay Martin\_\_\_ certify that:

1. They are the Vice President and Secretary, respectively, of THE MENLO COMMONS HOMEOWNERS ASSOCIATION, a California nonprofit mutual benefit corporation.

2. The Articles of Incorporation of this corporation are amended and restated to read as follows:

ARTICLE I  
NAME

The name of the corporation (hereinafter called the "Corporation" or the "Association") is THE MENLO COMMONS ASSOCIATION. The corporation is an association formed to manage a common interest development under the Davis-Stirling Common Interest Development Act.

ARTICLE II  
AGENT FOR SERVICE OF PROCESS

The name of the corporation's agent for service of process is Helen Olson. The address of the agent of the corporation is: 2140 Santa Cruz Avenue, Unit D-203, Menlo Park, CA 94025

ARTICLE III  
BUSINESS OFFICE AND MANAGING AGENT

The location of the business office of the corporation is: 2140 Santa Cruz Avenue, E-311 Menlo Park, CA 94025. The Common Interest Development is situated in the City of Menlo Park, San Mateo County, California. The name of the Association's managing agent is **Manor Association, Inc.** and the agent's address is 353 Main Street, Redwood City, CA 94063-1729.

*Law Offices of*  
Hanna & Van Atta  
525 UNIVERSITY AVENUE, SUITE 705  
PALO ALTO, CA 94301  
TELEPHONE (650) 321-5700

**ARTICLE IV  
NONPROFIT CORPORATION LAW OF 1980**

This corporation elects to be governed by all of the provisions of the Nonprofit Corporation Law of 1980 not otherwise applicable to it under Part 5 thereof.

**ARTICLE V  
PURPOSES OF THE ASSOCIATION**

This corporation is a nonprofit mutual benefit corporation organized under the Nonprofit Mutual Benefit Corporation Law.

The purpose of this corporation is to engage in any lawful act or activity, other than credit union business, for which a corporation may be organized under such Law.

This corporation does not contemplate pecuniary gain or profit to the Members thereof, and the specific purpose of this corporation is to provide for management, administration, maintenance, preservation and architectural control of the residential Units and Common Area within a certain tract of property situated in the City of Menlo Park, County of San Mateo, California, fronting on Santa Cruz Avenue, nearest cross street Sand Hill Road Zip Code 94025, and to promote the health, safety and welfare of all the residents within the property and any additions thereto as may hereafter be brought within the jurisdiction of this Association for this purpose, all according to that certain Enabling Declaration Establishing a Plan for Condominium Ownership, hereinafter called the "Declaration" recorded or to be recorded with respect to said property in the Office of the Recorder of San Mateo County, as required by § 1352 of the California Civil Code.

Notwithstanding any of the above statements of purposes and powers, this corporation shall not, except to an insubstantial degree, engage in any activities or exercise any powers that are not in furtherance of the specific purpose of this corporation.

**ARTICLE VI  
DISSOLUTION**

This Association is intended to qualify as a homeowners' association under the applicable provisions of the Internal Revenue Code, and of the Revenue and Taxation Code of California. No part of the net earnings of this organization shall inure to the benefit of any private individual, except as expressly provided in those sections with respect to the acquisition, construction, or provision for management, maintenance, and care of the Association property, and other than by a rebate of excess membership dues, fees, or Assessments. So long as there is any Unit, or Parcel for which the Association is obligated to provide management, maintenance, preservation or control, the Association shall not transfer all or substantially all of its assets or file a certificate of dissolution without the approval of one hundred percent (100%) of the Members. In the event of the dissolution, liquidation, or winding-up of the Association, upon or after termination of the project, in accordance with provisions of the Declaration, its assets remaining after payment, or provision for payment, of all debts and liabilities of the Association, shall be divided among and distributed to the Members in accordance with their respective rights therein.

**ARTICLE VII  
AMENDMENTS**

These Articles may be amended only by the affirmative vote of a majority of the Board, and by the affirmative vote (in person or by proxy) or written ballot of Members representing a majority of the total voting power of the Association.

3. The foregoing amendment and restatement of Articles of Incorporation has been duly approved by the Board of Directors.

4. The foregoing amendment and restatement of Articles of Incorporation has been duly approved by the required vote of Members.

We further declare under penalty of perjury under the laws of the State of California that the matters set forth in this certificate are true and correct of our own knowledge.

Date: 10 / 11 / 2005

Helen Olson  
Helen Olson, Vice President

Date: 10 / 11 / 2005

Kay Martin  
Kay Martin, Secretary



MENLO COMMONS  
 AMENDED AND RESTATED DECLARATION  
 TABLE OF CONTENTS

THIS DECLARATION CONTAINS A BINDING ARBITRATION PROVISION IN ACCORDANCE WITH THE FEDERAL ARBITRATION ACT AND/OR JUDICIAL REFERENCE CLAUSE THAT APPLIES TO CONSTRUCTION DEFECT CLAIMS. ARBITRATION AND JUDICIAL REFERENCE BOTH INCLUDE A WAIVER OF THE CONSTITUTIONAL RIGHT TO A JURY. YOU MUST READ THE PROVISIONS CAREFULLY AND SHOULD CONSULT LEGAL COUNSEL WITH ANY QUESTIONS.

IF THIS DOCUMENT CONTAINS ANY RESTRICTION BASED ON RACE, COLOR, RELIGION, SEX, FAMILIAL STATUS, MARITAL STATUS, DISABILITY, NATIONAL ORIGIN, OR ANCESTRY, THAT RESTRICTION VIOLATES STATE AND FEDERAL FAIR HOUSING LAWS AND IS VOID, AND MAY BE REMOVED PURSUANT TO SECTION 12956.1 OF THE GOVERNMENT CODE. LAWFUL RESTRICTIONS UNDER STATE AND FEDERAL LAW ON THE AGE OF OCCUPANTS IN SENIOR HOUSING OR HOUSING FOR OLDER PERSONS SHALL NOT BE CONSTRUED AS RESTRICTIONS BASED ON FAMILIAL STATUS.

*Law Offices of*  
 Hanna & Van Atta  
 525 UNIVERSITY AVENUE, SUITE 705  
 PALO ALTO, CA 94301  
 TELEPHONE (650) 321-3709

Page #

INTRODUCTORY PARAGRAPHS A thru C ..... 1

**ARTICLE I  
 DEFINITIONS**

1.1	Articles .....	2
1.2	Assessment .....	2
1.3	Assessment Lien .....	2
1.4	Association .....	2
1.5	Board or Board of Directors .....	2
1.6	Bylaws .....	2
1.7	Common Area(s) .....	2
1.8	Common Expenses .....	2
1.9	Common Interest .....	2
1.10	Condominium .....	2
1.11	Condominium Building .....	2
1.12	Condominium Documents .....	2
1.13	Condominium Plan .....	2

	<u>Page #</u>
1.14 Declaration .....	2
1.15 Eligible Mortgages .....	2
1.16 Eligible Mortgage Holder .....	3
1.17 Eligible Insurer or Guarantor .....	3
1.18 First Lender .....	3
1.19 First Mortgage .....	3
1.20 Foreclosure .....	3
1.21 Increment I .....	3
1.22 Increment II .....	3
1.23 Map .....	3
1.24 Member .....	3
1.25 Mortgage .....	3
1.26 Mortgagee .....	3
1.27 Mortgagor .....	3
1.28 Notice of Delinquent Assessment .....	3
1.29 Owner or Owners .....	3
1.30 Person .....	4
1.31 Project .....	4
1.32 Project Documents .....	4
1.33 Regular Assessments .....	4
1.34 Reimbursement Charge .....	4
1.35 Restricted Common Area .....	4
1.36 Rules .....	4
1.37 Special Assessments .....	4
1.38 Unit .....	4
1.39 Utility Facilities .....	4

**ARTICLE II  
DESCRIPTION OF PROJECT, DIVISION OF PROPERTY, AND  
CREATION OF PROPERTY RIGHTS**

2.1 Description of Project .....	4
2.2 Division of Property .....	4
A. Units .....	4
B. Common Areas .....	5
C. Restricted Common Areas, Grant of Exclusive Easements .....	5
2.3 Rights of Entry and Use .....	5
2.4 Partition Prohibited .....	6
2.5 All Easements Part of Common Plan .....	6

**ARTICLE III  
ASSOCIATION, ADMINISTRATION, MEMBERSHIP AND VOTING RIGHTS**

3.1 Association to Manage Common Areas .....	6
3.2 Membership .....	6
3.3 Transferred Membership .....	6
3.4 Membership and Voting Rights .....	6

**ARTICLE IV**



**MAINTENANCE AND ASSESSMENTS**

4.1	Creation of the Lien and Personal Obligation of Assessments .....	7
4.2	Purpose of Assessments .....	7
4.3	Assessments .....	7
	A. Regular Assessments .....	7
	B. Special Assessments .....	7
4.4	Restrictions on Increases in Regular or Special Assessments .....	8
	B. Assessments – Emergency Situations.....	8
	C. Notice and Quorum for Any Action Authorized Under Section 4.4.....	8
4.5	Division of Assessments .....	9
4.6	Annual Assessment; Due Dates .....	9
4.7	Effect of Nonpayment of Assessments .....	9
4.8	Transfer of Condominium by Sale or Foreclosure .....	9
4.9	Priorities; Enforcement; Remedies .....	9
	A. Statement of Charges.....	10
	B. Right to Request Meeting.....	10
	C. Notice of Delinquent Assessment.....	10
	D. Enforcement of Assessment Lien.....	11
4.10	Unallocated Taxes .....	12

**ARTICLE V**

**DUTIES AND POWERS OF THE ASSOCIATION**

5.1	Duties .....	12
	A. Maintenance .....	12
	B. Inspection and Maintenance Guidelines .....	14
	C. Insurance .....	14
	D. Discharge of Liens .....	14
	E. Assessments .....	14
	F. Payment of Expenses and Taxes .....	14
	G. Enforcement .....	14
5.2	Powers .....	15
	A. Utility Service .....	15
	B. Easements .....	15
	C. Manager .....	15
	D. Adoption of Rules .....	15
	E. Access .....	15
	F. Assessments and Liens .....	15
	G. Fines and Disciplinary Action .....	15
	H. Enforcement .....	16
	I. Acquisition and Disposition of Property .....	16
	J. Loans .....	16
	K. Dedication .....	16
	L. Contracts .....	16
	M. Delegation .....	16
	N. Security .....	17

P. Litigation/Arbitration..... 17  
Q. Other Powers ..... 17  
R. Common Area Improvements ..... 17

**ARTICLE VI  
UTILITIES**

6.1 Owners' Rights and Duties ..... 17  
6.2 Easements for Utilities and Maintenance ..... 18  
6.3 Association's Duties ..... 18

**ARTICLE VII  
USE RESTRICTIONS**

7.1 Senior Citizen Housing Development ..... 18  
7.2 Condominium Use ..... 18  
7.3 Nuisances ..... 19  
7.4 Permitted Vehicles and Parking ..... 19  
7.5 Signs ..... 20  
7.6 Animals ..... 21  
7.7 Garbage and Refuse Disposal ..... 21  
7.8 Radio and Television Antennas ..... 21  
7.9 Right to Lease; Limitations on Leasing ..... 21  
7.10 Architectural Control ..... 26  
7.11 Structural Integrity ..... 28  
7.12 Clothes Lines ..... 28  
7.13 Power Equipment and Motor Vehicle Maintenance ..... 28  
7.14 Liability of Owners for Damage to Common Area ..... 28  
7.15 Activities Causing Increase in Insurance Rates ..... 28  
7.16 Flags, Pennants, Banners, Etc. .... 29  
7.17 Floor Coverings..... 29  
7.18 Window Coverings..... 29  
7.19 Basketball Standards and Sports Apparatus..... 29  
7.20 Common Area Use ..... 29  
7.21 Keys and Locks ..... 29  
7.22 Owner's Right and Obligation to Maintain and Repair..... 29

**ARTICLE VIII  
INSURANCE; DAMAGE OR DESTRUCTION; CONDEMNATION**

8.1 Insurance ..... 30  
    A. Amount, Term and Coverage..... 31  
    B. Representation for Claims..... 31  
    D. Review of Policies..... 31  
    E. Separate Insurance Limitations..... 31  
    F. Copies of Policies; Notice to Members..... 32  
    G. Limitation on Liability..... 32  
    H. Policies and Procedures Regarding the Filing and Processing Claims..... 32  
8.2 Damage or Destruction ..... 32

A. Process for Repair or Reconstruction..... 33  
B. Process If Repair or Reconstruction Not Undertaken ..... 33  
8.3 Condemnation ..... 34

**ARTICLE IX  
GENERAL PROVISIONS**

9.1 Enforcement ..... 35  
9.2 Invalidity of Any Provision ..... 35  
9.3 Term ..... 35  
9.4 Amendments ..... 35  
9.5 Encroachment Rights ..... 35  
9.6 Rights of First Lenders ..... 36  
    A. Copies of Project Documents ..... 36  
    B. Audited Statement ..... 36  
    C. Notice of Action ..... 36  
    D. Consent to Action ..... 36  
    E. Right of First Refusal ..... 38  
    F. Contracts ..... 38  
    G. Reserves ..... 38  
    H. Priority of Liens ..... 38  
    I. Distribution of Insurance or Condemnation Proceeds ..... 38  
    J. Status of Loan to Facilitate Resale ..... 38  
    K. Right to Appear at Meetings ..... 38  
9.7 Owner's Compliance ..... 39  
9.8 Notice ..... 39  
9.9 Fair Housing ..... 39  
9.10 Dispute Resolution ..... 39  
9.11 Number; Gender ..... 40

- Exhibit – A Assessments Schedule (4 pages)
- Exhibit – B Items covered by Maintenance Provisions (1 page)
- Exhibit – C Civil Code Section 51.3 (4 pages)
- Exhibit – D The Plan (8 pages)



## MENLO COMMONS

### AMENDED AND RESTATED DECLARATION

The "Amended and Restated Declaration of Covenants, Conditions and Restrictions (CC&R) for Menlo Commons Association" recorded January 6, 1987, Document No. 87169708, Official Records of San Mateo County ("Amended Declaration"), imposing restrictions on that certain real property described on the Parcel Map, recorded September 20, 1976, in Volume 33 of Parcel Maps, page 27, San Mateo County Records ("Map"), and on the Condominium Plan attached as Exhibit "F" to the Declaration of Covenants, Conditions and Restrictions Establishing a Plan for Condominium Ownership" recorded March 11, 1977, in Volume 7405, page 331, Document No. 91155AK, and the Condominium Plan attached as Exhibit "F" to the "Amended and Restated Declaration of Covenants, Conditions and Restrictions for Menlo Commons Association" recorded January 6, 1987, Document No. 87169708 (collectively "Condominium Plan"), is amended pursuant to the approval of a majority of the voting power of the Menlo Commons Homeowners Association.

By this Amendment, the Members of the Association intend to, and do supersede the Amended Declaration in its entirety. Upon execution and recordation of this Declaration in the Office of the Recorder of the County of San Mateo, State of California, this Declaration shall be in full force and effect and the Amended Declaration shall cease to be of any force or effect (except that the Condominium Plan shall continue to be in effect, and is incorporated by reference herein Exhibit "D").

**THIS AMENDED DECLARATION**, made on the date hereinafter set forth, pursuant to approval of a majority of the Members of the Association, is made with reference to the following facts:

- A. This Declaration shall bind and benefit the "Project" as defined in section 1.31.
- B. The Members of the Association intend by this document to impose upon the Project mutually beneficial restrictions under a general plan of improvement for the benefit of all the Condominiums and the Owners thereof.
- C. This Project is a Senior Citizen Housing Development, as defined by California Civil Code section 51.3. All residents must be "qualified," as provided in more detail in section 7.1.

**NOW, THEREFORE**, the Members hereby declare that the Project shall continue to be held, conveyed, Mortgaged, encumbered, leased, rented, used, occupied, sold, and improved, subject to the following declarations, limitations, covenants, conditions, restrictions and easements, all of which are imposed as equitable servitudes pursuant to a general plan for the development of the Project for the purpose of enhancing and protecting the value and attractiveness of the Project, and every part thereof, in accordance with the plan for the improvements of the Project and the division thereof into Condominiums. All of the limitations, covenants, conditions, restrictions and easements shall constitute covenants which shall run with the land and shall be binding upon all parties having or acquiring any right, title or interest in or to any part of the Project or the property therein.

*Law Offices of  
Hanna & Van Atta*  
525 UNIVERSITY AVENUE, SUITE 705  
PALO ALTO, CA 94301  
TELEPHONE (415) 321-5700

## ARTICLE I DEFINITIONS

- 1.1 "Articles": The Articles of Incorporation of the Association, as amended from time to time.
- 1.2 "Assessment": That portion of the cost of maintaining, improving, repairing, operating and managing the Project which is to be paid by each Owner as determined by the Association and shall include regular and special assessments.
- 1.3 "Assessment Lien": Defined in section 4.9C.
- 1.4 "Association": The MENLO COMMONS ASSOCIATION, a California nonprofit mutual benefit corporation, the Members of which shall be the Owners of Condominiums in the Project.
- 1.5 "Board" or "Board of Directors": The governing body of the Association.
- 1.6 "Bylaws": The Bylaws of the Association, as amended from time to time.
- 1.7 "Common Area(s)": Parcel A and Parcel B, as described on the Map, title to each of which Parcel is held by the Owners of Units located within each Parcel, as tenants-in-common. The Common Area includes, without limitation, land; parking and driveway areas; trash enclosures; conduits, pipes, plumbing, wires, exterior sprinklers and sprinkler pipes, landscaping and other utility installations required to provide power, light, water, sewerage, drainage to the Common Area, and to the Units.
- 1.8 "Common Expenses": The actual and estimated expenses of operating the Common Area and any reasonable reserve for such purposes as found and determined by the Board and all sums designated Common Expenses by or pursuant to the Condominium Documents.
- 1.9 "Common Interest": The proportionate undivided interest in the Common Area that is part of each Condominium as set forth in this Declaration.
- 1.10 "Condominium": An estate in real property as defined in California Civil Code §§783 and 1351(f), consisting of an undivided interest in common in a portion of the Project and a separate interest in space called a Unit.
- "Condominium Building": A residential structure containing Units.
- 1.12 "Condominium Documents": The same as "Project Documents".
- 1.13 "Condominium Plan": The Condominium Plans which identify the Common Areas and each separate interest pursuant to California Civil Code §1351, described above in the first paragraph of this Declaration.
- 1.14 "Declaration": This Amended and Restated Declaration, as amended or supplemented from time to time.
- 1.15 "Eligible Mortgages": Mortgages held by "Eligible Mortgage Holders".

**1.16** "Eligible Mortgage Holder": A First Lender who has requested notice of certain matters from the Association in accordance with section 9.6C.

**1.17** "Eligible Insurer or Guarantor": An insurer or governmental guarantor of a First Mortgage who has requested notice of certain matters from the Association in accordance with section 9.6C.

**1.18** "First Lender": Any person, entity, bank, savings and loan association, insurance company, or financial institution holding a recorded First Mortgage on any Condominium.

**1.19** "First Mortgage": Any recorded Mortgage made in good faith and for value on a Condominium with first priority over other Mortgages encumbering the Condominium.

**1.20** "Foreclosure": The legal process by which a Condominium owned by an Owner who is in default under a Mortgage is sold pursuant to California Civil Code § 2924a et seq. or sale by the Court pursuant to California Code of Civil Procedure § 725a et seq. and any other applicable laws.

**1.21** Increment I: Parcel A of Parcel Map recorded September 30, 1976, Volume 33 of Parcel Maps, page 27, San Mateo County Records.

**1.22** Increment II: Parcel B of Parcel Map recorded September 30, 1976, in Volume 33 of Parcel Maps, page 27, San Mateo County Records.

**1.23** "Map": The Parcel Map filed for record the 30th day of September 1976, in Volume 33 of Parcel Maps at page 27 in the records of San Mateo County.

**1.24** "Member": A person entitled to membership in the Association as provided herein.

**1.25** "Mortgage": A Mortgage, deed of trust, assignment of rents, issues and profits or other proper instrument (including, without limitation, those instruments and estates created by sublease or assignment) given as security for the repayment of a loan or other financing which encumbers a Condominium, made in good faith and for value.

**1.26** "Mortgagee": The holder of a Mortgage including the beneficiary of a deed of trust that constitutes a Mortgage.

**1.27** "Mortgagor": A Person who encumbers his Condominium with a Mortgage, including a trustor of a deed of trust that constitutes a Mortgage.

**1.28** "Notice of Delinquent Assessment": A notice of delinquent assessment filed by the Association for a delinquent Assessment pursuant to section 4.9C.

**1.29** "Owner" or "Owners": The record holder of fee simple title to a Condominium, expressly excluding Persons having any interest merely as security for the performance of an obligation until such person obtains fee title thereto, and those parties who have leasehold interests in a Condominium. If a Condominium is sold under a recorded contract of sale, the purchaser under the contract of sale, rather than the holder of the fee interest, shall be considered the "Owner" from and after the date the Association receives written notice of the recorded contract.

**1.30** "Person": A natural person, a corporation, a partnership, a trust, or other legal entity.

**1.31** "Project": All of the real property described on the Map and all improvements thereon, subject to this Declaration.

**1.32** "Project Documents": This Declaration, as amended from time to time, the exhibits, if any, attached hereto, together with the other basic documents used to create and govern the Project, including the Map, the Articles, the Bylaws, and the Condominium Plan and Rules adopted by the Board or the Association.

**1.33** "Regular Assessments": A Regular Assessment levied by the Association pursuant to section 4.3A.

**1.34** "Reimbursement Charge": A charge levied by the Board against an Owner to reimburse the Association for costs and expenses incurred in bringing the Owner and/or his or her Unit into compliance with the provisions of this Declaration, determined and levied pursuant to section 4.9 of this Declaration.

**1.35** "Restricted Common Area": Those portions of the Common Area set aside for exclusive use of a Unit Owner or Owners, pursuant to section 2.2C, and shall constitute "Exclusive Use Common Area" within the meaning of California Civil Code § 1351(i).

**1.36** "Rules": The rules adopted from time to time by the Association pursuant to section 5.2D.

**1.37** "Special Assessments": A Special Assessment levied by the Association pursuant to section 4.3B.

**1.38** "Unit": A Condominium, as defined in section 2.2A, which is not owned in common with the Owners of other Condominiums in the Project. Each Unit is identified by separate Unit letter and number on the Map and Condominium Plan.

**1.39** "Utility Facilities": Defined in section 6.1.

## ARTICLE II DESCRIPTION OF PROJECT, DIVISION OF PROPERTY, AND CREATION OF PROPERTY RIGHTS

**2.1 Description of Project:** The Project is a condominium project consisting of the land, the one hundred and twenty-two (122) Condominiums and all other improvements thereon.

**2.2 Division of Property:** The Project is divided as follows:

**A. Units:** Each of the Units as separately shown, numbered and designated on the Map and on the Condominium Plan, consists of the space bounded by and contained within the boundaries described on the Map and Condominium Plan, and includes all improvements contained within the space so described, each of such spaces being defined and referred to herein as a "Unit." Balconies are included in the Units. Each Unit includes both the portions of the building so described and the airspace so encompassed. The Unit does not include those areas and those things which are defined as "Common Area" in section 1.7. Each Unit is subject to such encroachments as are contained in the building, whether the same now exist or may



be later caused or created in any manner referred to in section 9.5. In interpreting deeds and Condominium Plans, the then existing physical boundaries of a Unit, when the boundaries of the Unit are contained within a building, or of a Unit reconstructed in substantial accordance with the original plans thereof shall be conclusively presumed to be its boundaries rather than the boundaries expressed in the deed or Condominium Plan, regardless of settling or lateral movement of the building and regardless of minor variance between boundaries shown on the plan or deed, and those of the building. Each Unit shall have appurtenant to it nonexclusive rights for ingress, egress and support through the Common Area subject further to the rights of each Owner in the Restricted Common Area appurtenant to that Owner's Condominium.

**B. Common Areas:** The remainder of the Project constitutes "Common Area" as defined in section 1.7.

Each Condominium Owner shall have, as appurtenant to his or her Unit, a percentage undivided interest in a portion of the Common Area as provided in Exhibit "A" attached hereto. The Common Interest appurtenant to each Unit is declared to be permanent in character and cannot be altered without the consent of all the Owners affected, as expressed in an amended Declaration. The undivided Common Interest cannot be separated from the Unit, and any conveyance or transfer of the Unit shall include the undivided Common Interest, the Owner's membership in the Association, and any other benefits or burdens appurtenant to that Owner's Condominium. Subject to this Declaration and the Rules, each Owner may have access to and use of the Common Areas in accordance with the purposes for which they are intended without hindering the exercise of or encroaching upon the rights of any other Owners subject to the rights of each Owner in the Restricted Common Area appurtenant to that Owner's Condominium.

**C. Restricted Common Areas, Grant of Exclusive Easements:** Portions of the Common Area consisting of parking spaces located beneath Condominium Buildings (hereinafter "Garage Parking Spaces"), referred to as "Restricted Common Areas," are set aside and allocated for the exclusive use of the Owners of the Condominiums.

Each Restricted Common Area Garage Parking Space is marked by the unit number of the Unit to which it is assigned.

The exclusive use of at least one (1) Garage Parking Space has been granted by recorded deed to the Owner of each Unit,

Extra Garage Parking Spaces, marked HOA 1-4 in Building C and HOA 5-9 in Building D, may be rented for a fee set by the Board of Directors.

**2.3 Rights of Entry and Use:** The Units and Common Area (including Restricted Common Area) shall be subject to the following rights of entry and use:

A. The non-exclusive rights of each Owner for ingress, egress and support through the Common Area, and use of the Common Area as provided in sections 2.2A and 2.2B.

B. The right of the Association's agents or employees to enter any Unit to cure any violation of this Declaration or the Bylaws, provided that the Owner has received notice and a hearing as required by the Bylaws (except in the case of an emergency) and the Owner has failed to cure the violation or take steps necessary to cure the violation within thirty (30) days after the finding of a violation by the Association.

C. The access rights of the Association to maintain, repair or replace improvements or property located in the Common Area as described in section 5.2E.

D. The rights of the Owners and the Association to install, maintain, repair or replace utilities as described in Article VI.

E. The encroachment rights described in section 9.5.

F. The rights of Owners to make improvements or alterations authorized by California Civil Code § 1360(a)(2), subject to the provisions of section 7.10.

**2.4 Partition Prohibited:** The Common Areas shall remain undivided as set forth above. Except as provided by California Civil Code §1359 or authorized under sections 8.2B or 8.3, no Owner shall bring any action for partition of the Common Area, it being agreed that this restriction is necessary in order to preserve the rights of the Owners with respect to the operation and management of the Project. Judicial partition by sale of a single Condominium owned by two (2) or more persons and division of the sale proceeds is not prohibited hereby.

**2.5 All Easements Part of Common Plan:** Whenever any easements are reserved or created or are to be reserved or created herein, such easements shall constitute equitable servitudes for the mutual benefit of all property in the Project, even if only certain Units are specifically mentioned as subject to or benefiting from a particular easement, and when easements referred to herein are subsequently created by grant deeds, such easements are part of the common plan created by this Declaration for the benefit of all property Owners within the Project.

### ARTICLE III ASSOCIATION, ADMINISTRATION, MEMBERSHIP AND VOTING RIGHTS

**3.1 Association to Manage Common Areas:** The management of the Common Area shall be vested in the Association in accordance with its Bylaws. The Owners of all the Condominiums covenant and agree that the administration of the Project shall be in accordance with the provisions of this Declaration, and the Articles and Bylaws.

**3.2 Membership:** The Owner of a Condominium shall automatically, upon becoming the Owner of same, be a Member of the Association, and shall remain a Member thereof until such time as the ownership ceases for any reason, at which time the membership in the Association shall automatically cease. Membership shall be held in accordance with the Articles and Bylaws.

**3.3 Transferred Membership:** Membership in the Association shall not be transferred, encumbered, pledged, or alienated in any way, except upon the sale or encumbrance of the Condominium to which it is appurtenant, and then only to the purchaser, in the case of a sale, or Mortgagee, in the case of an encumbrance of such Condominium. On any transfer of title to an Owner's Condominium, including a transfer on the death of an Owner, the membership passes automatically along with title to the transferee. A Mortgagee does not have membership rights until it obtains title to the Condominium by Foreclosure or deed in lieu thereof. Any attempt to make a prohibited transfer is void. No Member may resign his or her membership. On notice of a transfer, the Association shall record the transfer on its books.

**3.4 Membership and Voting Rights:** Membership and voting rights shall be as provided in the Bylaws.

**ARTICLE IV  
MAINTENANCE AND ASSESSMENTS**

**4.1 Creation of the Lien and Personal Obligation of Assessments:** Each Owner of each Condominium within the Project, hereby covenants, and each Owner of any Condominium by acceptance of a deed for that Condominium, whether or not it shall be so expressed in such deed, covenants and agrees:

(1) to pay Regular Assessments, Special Assessments and Reimbursement Charges to the Association as established in this Declaration; and

(2) to allow the Association to enforce any Assessment Lien established under this Declaration by nonjudicial proceedings under a power of sale or by any other means authorized by law.

The Regular and Special Assessments, including Reimbursement Charges, together with interest, late charges, collection costs and reasonable attorneys' fees, shall be a charge on the Condominium and shall be a continuing Assessment Lien upon the Condominium against which each such Assessment is made, the lien to become effective upon recordation of a Notice of Delinquent Assessment. Each Assessment, together with interest, late charges, collection costs, and reasonable attorneys' fees, shall also be the personal obligation of the person who was the Owner of such Condominium at the time when the Assessment fell due. The personal obligation for delinquent Assessments shall not pass to his or her successors in title unless expressly assumed by them. No Owner shall be exempt from liability for payment of Assessments by waiver of the use or enjoyment of any of the Common Areas or by the abandonment of the Owner's Condominium.

The interest of any Owner in the amounts paid pursuant to any Assessment upon the transfer of ownership shall pass to the new Owner. Upon the termination of these covenants for any reason, any amounts remaining from the collection of such Assessments after paying all amounts properly charged against such Assessments shall be distributed to the then Owners on the same pro rata basis on which the Assessments were collected.

**4.2 Purpose of Assessments:** The Assessments levied by the Association shall be used exclusively to promote the economic interests, recreation, health, safety, and welfare of all the Owners and other residents in the Project and to enable the Association to perform its obligations hereunder.

**4.3 Assessments:**

**A. Regular Assessments:** The Board shall establish and levy Regular Assessments in an amount that the Board estimates will be sufficient to raise the funds needed to perform the duties of the Association during each fiscal year.

The Regular Assessment shall include a portion for reserves in such amounts as the Board in its discretion considers appropriate to meet the costs of the future repair, replacement or additions to the major improvements and fixtures that the Association is obligated to maintain and repair. Reserve funds shall be deposited in a separate account and the signatures of at least two (2) persons who shall either be members of the Board or one officer who is not a member of the Board and a member of the Board shall be required to withdraw monies from the reserve account.

**B. Special Assessments:** The Board, at any time, may levy a Special Assessment in order to raise funds for unexpected operating or other costs, insufficient operating or reserve funds, or such other purposes as the Board in its discretion considers appropriate. Special Assessments shall be allocated among the Units in the same manner as Regular Assessments.

**4.4 Restrictions on Increases in Regular Assessments or Special Assessments:**

**A.** Except as provided in section 4.4B, without having first obtained the approval of such action by the vote or written assent of Members casting a majority of the votes at a meeting of the Association at which a quorum is present, the Board may not: (1) impose a Regular Assessment on any Condominium which is more than twenty percent (20%) greater than the Regular Assessment for the immediately preceding fiscal year or (2) levy a Special Assessment to defray the cost of any action or undertaking on behalf of the Association which in the aggregate exceeds five percent (5%) of the budgeted gross expenses of the Association for that fiscal year. For purposes of this section 4.4, a "quorum" means Members constituting more than fifty percent (50%) of the voting power of the Association. Any meeting of the Association for purposes of complying with this section 4.4 shall be conducted in accordance with Chapter 5 (commencing with § 7510) of Part 3, Division 2 of Title 1 of the California Corporations Code and § 7613 of the California Corporations Code. The right of the Board to increase Regular Assessments by up to twenty percent (20%) over the Regular Assessment for the immediately preceding fiscal year is subject to the Board having complied with the provisions of California Civil Code § 1365(a), which provisions are set forth in section 12.1(1) of the Bylaws or having obtained the approval of such increase by the Members in the manner set forth above in this section 4.4.

**B. Assessments - Emergency Situations.** Notwithstanding the foregoing, the Board, without membership approval, may increase Regular Assessments or levy Special Assessments necessary for an emergency situation in amounts that exceed the provisions of section 4.4A, above. For purposes of this section, an emergency situation is one of the following:

- (1) an extraordinary expense required by an order of a court,
- (2) an extraordinary expense necessary to repair or maintain the Project or any part of it for which the Association is responsible where a threat to personal safety on the Project is discovered, or
- (3) an extraordinary expense necessary to repair or maintain the Project or any part of it for which the Association is responsible that could not have been reasonably foreseen by the Board in preparing and distributing the pro forma operating budget, provided, however, that prior to the imposition or collection of the Assessment, the Board shall pass a resolution containing written findings as to the necessity of the extraordinary expense involved and why the expense was not or could not have been reasonably foreseen in the budgeting process and the resolution shall be distributed to the Members with the notice of the Assessment.

The Association shall provide to the Owners by first-class mail notice of any increase in the Regular Assessments or Special Assessments of the Association, not less than thirty (30) nor more than sixty (60) days prior to the increased Assessment becoming due.

This section 4.4 incorporates the statutory requirements of California Civil Code § 1366. If this section of the California Civil Code is amended in any manner, this section 4.4 shall be automatically amended in the same manner without the necessity of amending this Declaration.

**C. Notice and Quorum for Any Action Authorized Under Section 4.4:** Any action authorized under section 4.4, which requires a vote of the membership, shall be taken at a meeting called for that purpose, written notice of which shall be personally delivered or mailed to all Members not less than ten (10) nor more than ninety (90) days in advance of the meeting specifying the place, day and hour of the meeting and, in the case of a special meeting, the nature of the business to be undertaken. The action may also be taken without a meeting pursuant to the provisions of California Corporations Code §7513.

**4.5 Division of Assessments:** Both Regular Assessments and Special Assessments shall be levied among the Condominiums as provided in Exhibit "A" attached hereto. Regular Assessments shall be collected on a monthly basis unless the Board directs otherwise. Special Assessments may be collected in one (1) payment or periodically as the Board shall direct.

**4.6 Annual Assessment; Due Dates:** The Board of Directors shall use its best efforts to fix the amount of the Regular Assessment against each Condominium and send written notice thereof to every Owner at least forty-five (45) days in advance of each Regular Assessment period, provided that failure to comply with the foregoing shall not affect the validity of any Assessment levied by the Board. Regular Assessments may be prorated on a monthly basis. The due dates shall be established by the Board of Directors. The Association shall, upon demand, and for a reasonable charge, furnish a certificate signed by an officer or designated representative of the Association stating that the Assessments on a specified Condominium have been paid. Such a certificate shall be conclusive evidence of such payment.

**4.7 Effect of Nonpayment of Assessments:** Any Assessment not paid within fifteen (15) days after the due date shall be delinquent, shall bear interest at the rate of twelve percent (12%) per annum commencing thirty (30) days after the due date until paid, and shall incur a late payment penalty in an amount to be set by the Board from time to time, not to exceed the maximum permitted by applicable law.

**4.8 Transfer of Condominium by Sale or Foreclosure:** Sale or transfer of any Condominium shall not affect the Assessment Lien. However, the sale of any Condominium pursuant to Foreclosure of a First Mortgage shall extinguish the Assessment Lien of any Assessments on that Condominium (including attorneys' fees, late charges, or interest levied in connection therewith) as to payments which became due prior to such sale or transfer (except for Assessment Liens as to which a Notice of Delinquent Assessments has been recorded prior to the Mortgage). No amendment of the preceding sentence may be made without the consent of Owners of Condominiums to which at least sixty-seven percent (67%) of the votes in the Association are allocated, and the consent of the Eligible Mortgage Holders holding First Mortgages on Condominiums comprising fifty-one percent (51%) of the Condominiums subject to First Mortgages. No sale or transfer shall relieve such Condominium from liability for any Assessments thereafter becoming due or from the lien thereof.

The unpaid share of such Assessments shall be deemed to be Common Expenses collectible from all of the Condominium Owners including such acquirer, his or her successors or assigns.

The Association shall have the right to inspect the interior of a Unit that has been, or is about to be, conveyed to check the condition of drain lines, fans, HVAC equipment and to make or require the Owner(s) to make repairs to or replace defective equipment, at the expense of the Owner(s) with respect to appliances and equipment.

If a Condominium is transferred, the grantor shall remain liable to the Association for all unpaid Assessments against the Condominium through and including the date of the transfer. The grantee shall be entitled to a statement from the Association, dated as of the date of transfer, setting forth the amount of the unpaid Assessments against the Condominium to be transferred and the Condominium shall not be subject to a lien for unpaid Assessments in excess of the amount set forth in the statement, provided, however, the grantee shall be liable for any Assessments that become due after the date of the transfer.

**4.9 Priorities; Enforcement; Remedies:** If an Owner fails to pay an Assessment when due, the Association has the right, and option, to bring legal action against the Owner to

enforce collection of the unpaid and past due Assessment, or may impose an Assessment Lien on the Unit owned by Owner pursuant to the provisions of Civil Code §§ 1367 and 1367.1. Suit to recover a money judgment for unpaid Assessments and attorneys' fees, shall be maintainable without foreclosing or waiving the lien securing the same. The Association shall distribute the written notice described in subdivision (b) of Civil Code § 1365.1 entitled "Notice Assessments and Foreclosure" to each Member during the 60-day period immediately preceding the beginning of the Association's fiscal year. The notice is to be printed in at least 12-point type.

**A. Statement of Charges.** At least 30 days prior to the Association recording an Assessment Lien upon a Unit pursuant to Civil Code § 1367.1(a), the Association shall notify the owner of record in writing by certified mail of the following:

(1) A general description of the collection and lien enforcement procedures of the Association and the method of calculation of the amount owed, a statement that the Owner has the right to inspect the Association's records, pursuant to section 8333 of the Corporations Code, and the following statement in 14-point boldface type, if printed, or in capital letters, if typed: "IMPORTANT NOTICE: IF YOUR SEPARATE INTEREST IS PLACED IN FORECLOSURE BECAUSE YOU ARE BEHIND IN YOUR ASSESSMENTS, IT MAY BE SOLD WITHOUT COURT ACTION".

(2) An itemized statement of the charges owed by the Owner, including items on the statement which indicate the amount of any delinquent assessments, the fees and reasonable costs of collection, reasonable attorney's fees (not to exceed \$425.00 per Civ. Code § 1366.3(a)), any late charges, and interest, if any.

(3) A statement that the Owner shall not be liable to pay the charges, interest, and costs of collection, if it is determined the Assessment was paid on time to the Association.

(4) The right to request a meeting with the Board as provided by Civil Code §1371.1(c).

Note: Any payments made by the Owner toward the debt shall first be applied to the Assessments owed, and, only after the Assessments owed are paid in full shall the payments be applied to the fees and costs of collection, attorneys' fees, late charges, or interest. When an Owner makes a payment, the owner may request a receipt and the Association shall provide it. The receipt shall indicate the date of payment and the person who received it. The Association shall provide a mailing address for overnight payment of Assessments.

**B. Right to Request Meeting.** An Owner may dispute the debt noticed pursuant to section 4.9A, above, submitting to the Board a written explanation of the reasons for his or her dispute. The Board shall respond in writing to the Owner within 15 days of the date of the postmark of the explanation, if the explanation is mailed within 15 days of the postmark of the notice. The Owner may submit a written request to meet with the Board to discuss a payment plan for the debt noticed pursuant to section 4.9A, above. The Board shall provide the Owner the standards for payment plans, if any exist. The Board shall meet with the Owner in executive session within 45 days of the postmark of the request, if the request is mailed within 15 days of the date of the postmark of the notice, unless there is no regularly scheduled Board meeting within that period, in which case the Board may designate a committee of one or more members to meet with the Owner.

**C. Notice of Delinquent Assessment.** After compliance with the provisions of Civil Code § 1367.1(a), the Association may record a Notice of Delinquent Assessment and establish an Assessment Lien against the Condominium of the delinquent Owner prior and superior to all other liens recorded subsequent to the Notice of Delinquent Assessment, except

(1) all taxes, bonds, assessments and other levies which, by law, would be superior thereto, and (2) the lien or charge of any First Mortgage of record recorded prior to the Notice of Delinquent Assessment. The Notice of Delinquent Assessment shall state the amount of the Assessment, collection costs, attorneys' fees, late charges and interest, a description of the Condominium against which the Assessment and other sums are levied, the name of the record Owner, and the name and address of the trustee authorized by the Association to enforce the lien by sale. The notice shall be signed by any officer of the Association or any management agent retained by the Association and shall be mailed in the manner set forth in Civil Code § 2924b to all record owners of the Unit no later than ten (10) days after recordation.

Within twenty-one (21) days after payment of the sums specified in the Notice of Delinquent Assessment, the Association shall record or cause to be recorded in the Office of the County Recorder in which the Notice of Delinquent Assessment is recorded a lien release or notice of rescission and provide the Owner a copy of the lien release or notice that the delinquent assessment has been satisfied.

**D. Enforcement of Assessment Lien.** Thirty (30) days following the recordation of the Notice of Delinquent Assessment, the Assessment Lien may be enforced in any manner permitted by law, including sale by the court, sale by the trustee designated in the Notice of Delinquent Assessment, or sale by a trustee substituted pursuant to California Civil Code § 2934(a). Any sale by the trustee shall be conducted in accordance with the provisions of §§ 2924, 2924b, 2924c, 2924f, 2924g, 2924h and 2924j of the California Civil Code applicable to the exercise of powers of sale in Mortgages and deeds of trust, including any successor statutes thereto, or in any other manner permitted by law. The fees of a trustee may not exceed the amounts prescribed in Civil Code §§ 2924c and 2924d. Nothing in this Declaration shall preclude the Association from bringing an action directly against an Owner for breach of the personal obligation to pay Assessments.

The Association, acting on behalf of the Condominium Owners, shall have the power to bid for the Condominium at Foreclosure sale, and to acquire and hold, lease, Mortgage and convey the Condominium. If the purchase of a Condominium would result in a five percent (5%) or greater increase in Assessments, the purchase shall require the vote or written consent of a majority of the total voting power of the Association, including a majority of Members other than Declarant. During the period a Condominium is owned by the Association, following Foreclosure:

- (1) no right to vote shall be exercised on behalf of the Condominium;
- (2) no Assessment shall be assessed or levied on the Condominium; and
- (3) each other Condominium shall be charged, in addition to its usual Assessment, its share of the Assessment that would have been charged to such Condominium had it not been acquired by the Association as a result of Foreclosure.

After acquiring title to the Condominium at Foreclosure sale following notice and publication, the Association may execute, acknowledge and record a deed conveying title to the Condominium which deed shall be binding upon the Owners, successors, and all other parties.

The Board may temporarily suspend the voting rights of a Member who is in default in payment of any Assessment, after notice and hearing, as provided in the Bylaws.

In conformity to Civil Code §1367(c), fines and penalties imposed by the Association for violation of this Declaration as a disciplinary measure for failure of an Owner to comply with this Declaration or the Rules, except for late payments, are not "Assessments," and are not enforceable by Assessment Lien, but are enforceable by court proceedings; provided, however, pursuant to Civil Code § 1367(b), monetary penalties imposed by the Association to reimburse the Association for

costs incurred for repair of damage to Common Area or facilities for which the Owner, or guests or tenants of an Owner, were responsible may become the subject of a lien. In the event that Civil Code §1367(c) is amended to permit fines and penalties imposed by the Association for violation of this Declaration as a disciplinary measure for failure of an Owner to comply with this Declaration or the Rules to be enforceable by Assessment Lien, then this provision shall be deemed amended to conform to any such amendment of Civil Code §1367(c).

**4.10 Unallocated Taxes:** In the event that any taxes are assessed against the Common Area, or the personal property of the Association, rather than against the Condominiums, said taxes shall be included in the Assessments made under the provisions of section 4.1 and, if necessary, a Special Assessment may be levied against the Condominiums in an amount equal to said taxes, to be paid in two (2) installments, thirty (30) days prior to the due date of each tax installment.

## ARTICLE V DUTIES AND POWERS OF THE ASSOCIATION

**5.1 Duties:** In addition to the duties enumerated in the Bylaws, or elsewhere provided for in this Declaration, and without limiting the generality thereof, the Association shall perform the following duties:

**A. Maintenance:** The Association shall maintain, repair, replace (when necessary), restore, operate and manage all of the Common Area and all facilities (including Utility Facilities to the extent described in section 6.3), improvements, equipment, hardscape, including concrete planters, wooden planter boxes, landscaping and irrigation thereon, furniture, fixtures and appliances in all Common Areas, and all property that may be acquired by the Association. The Association shall maintain the Units, including, without limitation, the structure surrounding all units, bearing walls, roofing, carport structures, ground-level patios; fencing, balconies, planter boxes and railings thereon, sidewalks, pathways and railings, mailboxes and mailbox structures, exterior lighting; exterior irrigation systems; window glass and exterior doors (including glass therein), columns, girders, subfloors; roofs, skylights, rain gutters and downspouts; foundations; storage buildings, conduits, ductwork, pipes, plumbing, wires and other utility installations required to provide or transport power, light, telephone, television and Internet cable service, gas, water, sewage and drainage; fire extinguishers; easement or grants for passage; repair or maintenance; and all exterior sewer, water or other utilities serving the property. The allocation of responsibility for maintenance of certain specific items is as provided in Exhibit "B" attached hereto.

(1) Maintenance shall include, without limitation, painting, maintaining, cleaning, repairing and replacing of all such areas.

(2) The responsibility of the Association for maintenance and repair shall not extend to repairs or replacements arising out of or caused by the willful or negligent act or omission of an Owner, or his or her guests, tenants or invitees or the Owner's pets, except if the repair is covered by the insurance carried by the Association, the Association shall be responsible for making the repairs, and the responsible Owner shall pay any deductible pursuant to the insurance policy. If the Owner fails to make such payment, then the Association may make such payment and shall charge the responsible Owner a Reimbursement Charge for reimbursement of such payment, which charge shall bear interest at the rate of twelve percent (12%) per annum (but no greater than the maximum rate allowed by law) until paid in full. Any repairs arising out of or caused by the willful or negligent act of an Owner, or his or her guests, tenants or invitees, or the Owner's pets, the cost of which is not covered by insurance carried by the Association, shall be made by the responsible Owner, provided the Board approves the person actually making the repairs and the method of repair. If the responsible Owner fails to take the necessary steps to make the repairs within a reasonable time under the circumstances, the Association shall make the repairs



and charge the cost thereof as a Reimbursement Charge to the responsible Owner, which cost shall bear interest at the rate of twelve percent (12%) per annum (but no greater than the maximum rate authorized by law) until paid in full. If an Owner disputes his or her responsibility for the repairs, the Owner shall be entitled to notice and a hearing as provided in the Bylaws before any charge may be imposed.

(3) The Association shall have the Common Area periodically inspected for wood-destroying pests and organisms and shall take appropriate corrective measures therefor. The Association shall have the authority to require the temporary removal of occupants of a Unit as may be necessary in connection with the treatment of wood-destroying pests or organisms, pursuant to the procedures described in Civil Code § 1364(d) or any successor statute thereto. The costs of any temporary relocation shall be borne by each Owner of a Unit who is required to temporarily relocate.

(4) Landscaping maintenance shall include regular fertilization, irrigation, pruning, and other prudent garden management practice necessary to promote a healthy weed-free environment for optimum plant growth. The Association shall remove and replace all dying or dead vegetation. The Association shall take appropriate steps to maintain the irrigation of the landscaping and to prevent damage resulting from misdirected and/or excessive watering.

(5) In order to reduce the presence of mold, fungi, spores, pollens and other botanical substances, or other allergens (collectively "Mold"), within the dwellings and Common Area, the Association shall inspect the exterior of the dwellings and the Common Area improvements not less frequently than once each year to check for water leaks or other breaches of the watertight integrity of the improvements, and for the presence of Mold. If any water leaks and/or Mold are detected, the Board shall immediately make recommendations for appropriate corrective steps to repair the leak, and/or remove the Mold and to maintain proper ventilation within enclosed areas, and to maintain humidity levels to reduce the risk of Mold growth. The Board shall decide in its best judgment whether to take corrective action, or, depending upon the estimated cost, refer the matter to the Members for a vote. The Board shall periodically inspect the irrigation system to ensure proper watering, and to correct any leaks and/or misdirected or excessive watering, and periodically inspect the ground surface around the foundations to ensure that no water is pooling around or within the foundations, and shall maintain rain gutters in a clean and proper operating condition at all times, and take such other prudent steps as may be appropriate to prevent Mold growth, or eliminate any existing Mold.

(6) Each Owner and occupant shall fully cooperate with the agents of the Association in the performance of the Association's maintenance and repair obligations described above. Such cooperation shall include, but is not limited to, immediate notification to the Board or its managing agent of any maintenance or repair problems for which the Association is responsible and access to the Owner or occupant's dwelling and Restricted Common Area as may be necessary to inspect and, if appropriate, to perform any necessary maintenance or repairs.

(7) In the event of any water leak or overflow from any Unit that damages any Common Area or other Unit, the Owner and occupants of the Unit that is the source of the water leak or overflow (the "Responsible Owner") shall cooperate with the Association in the inspection and correction of the problem. Cooperation shall include access to the dwelling to inspect and to correct the problem and/or repair any damage. The Responsible Owner shall reimburse the Association for its repair cost to the extent the cost is not paid through insurance maintained by the Association (provided that the Board shall have complete discretion as to the filing of claims with the Association's insurer), and the Association may levy a reimbursement assessment to recover the cost. If the damage may be covered by insurance maintained by the Association, the Association shall submit an appropriate claim. Any deductible amount shall be paid by the Responsible Owner.

**B. Inspection and Maintenance Guidelines:**

(1) The Board shall adopt inspection and maintenance guidelines for the periodic inspection and maintenance of the Common Area improvements and landscaping, including, but not limited to, foundations, gutters, down-spouts, siding, trim, roofs, balconies, window caulking, utility equipment and sanitary sewer and storm drainage facilities maintained by the Association, streets, parking areas, recreational facilities, and the irrigation system. The Board periodically and at least once every three years shall review and update the inspection and maintenance guidelines. The Board shall take all appropriate steps to implement and comply with the inspection and maintenance guidelines.

(2) The Association shall cause professional inspections of all infrastructure to be routinely made. Inspections shall be made at least yearly, and for appropriate items or events, more often. Inspections will include a review of all repair records since the previous inspection.

(3) The inspections shall be reported at the annual membership meeting and in writing, and shall include recommendations for cleaning, maintenance, repair, replacement, etc. (if any), as well as opinions of the costs. The reports shall address any noted deterioration which may require future attention. The reports may also recommend supplemental specialized investigations (i.e., elevator, termite, pool, mechanical, arborist, geologist, structural, etc).

(4) The Association shall keep permanent records of all: (a) Complaints and potential problems, including description, date and by whom; (b) Reports, including inspections and recommendations; (c) Repairs, including description, location, date, by whom made and cost; and (d) Plans, including construction drawings, subsequent modifications, and repair plans.

**C. Insurance:** The Association shall maintain such policy or policies of insurance as are required by section 8.1 of this Declaration.

**D. Discharge of Liens:** The Association shall discharge by payment, if necessary, any lien against the Common Area, and charge the cost thereof to the Member or Members responsible for the existence of the lien (after notice and a hearing, as provided in the Bylaws).

**E. Assessments:** The Association shall fix, levy, collect and enforce Assessments as set forth in Article IV hereof.

**F. Payment of Expenses and Taxes:** The Association shall pay all expenses and obligations incurred by the Association in the conduct of its business including, without limitation, all licenses, taxes or governmental charges levied or imposed against the property of the Association.

**G. Enforcement:** The Association shall be responsible for the enforcement of this Declaration.

The Association shall maintain and operate the Common Area of the Project in accordance with all applicable municipal, state, and federal laws, statutes and ordinances, as the case may be. The Association shall also, as a separate and distinct responsibility, take reasonable action to require that third parties (including Owners and their guests) utilize the Common Area in

accordance with the aforementioned laws. The Association shall, when it becomes aware of any violation of the aforementioned laws, take reasonable action to expeditiously correct such violations.

**5.2 Powers:** In addition to the powers enumerated in the Articles and Bylaws, or elsewhere provided for herein, and without limiting the generality thereof, the Association shall have the following powers:

**A. Utility Service:** The Association shall have the authority (but not the obligation) to obtain, for the benefit of all of the Condominiums, all water, gas and electric service, refuse collection, janitorial or window cleaning service, and CATV.

**B. Easements:** The Association shall have authority, by document signed by the President and the Secretary, and approved by the Board to grant easements in addition to those shown on the Map, where necessary for utilities, communication services, cable television, and sewer facilities over the Common Area to serve the common and open space areas and the Condominiums.

**C. Manager:** The Association may employ a manager or other persons and contract with independent contractors or managing agents to perform all or any part of the duties and responsibilities of the Association, provided that any contract with a firm or person appointed as a manager or managing agent shall not exceed a one (1) year term, and shall provide further that the authority of the Board to delegate its duties and responsibilities is limited, as provided in section 5.2M.

**D. Adoption of Rules:** The Board or the Members of the Association by majority vote, may adopt reasonable Rules that are not inconsistent with this Declaration relating to the use of the Common Area and all its facilities, and the conduct of Owners and their tenants, guests, and pets, with respect to the Project and other Owners. The Rules shall include, without limitation, the procedures to be followed by the Board and the Owners in complying with the limitations on occupancy, transfer, and rental of Units. Written copies of such Rules and any schedule of fines and penalties adopted by the Board shall be furnished to Owners, and shall be posted in a conspicuous place within the Common Area. The Rules shall be enforceable to the same extent as provisions of the Declaration and Bylaws.

**E. Access:** For the purpose of performing construction, maintenance or emergency repair for the benefit of the Common Area or the Owners in common, and/or to perform maintenance work that an Owner has failed to perform as provided in section 7.22, the Association's agents or employees shall have the right, after reasonable notice (not less than twenty-four (24) hours except in emergencies) to the Owner of the Unit in which maintenance work has not been performed, to enter any such Unit or to enter any portion of the Common Area at reasonable hours. Such entry shall be made with as little inconvenience to the Owner as practicable and any damage caused by such entry shall be repaired by the Board at the expense of the Association.

**F. Assessments and Liens:** The Board shall have the power to levy and collect Assessments in accordance with the provisions of Article IV hereof.

**G. Fines and Disciplinary Action:** The Board may impose fines or take disciplinary action against any Owner for failure to pay Assessments or for violation of any provision of the Condominium Documents and the Rules. Penalties may include, but are not limited to, fines, temporary suspension of voting rights, or other appropriate discipline, provided the Member is given notice and a hearing as provided in the Bylaws before the imposition of any fine or disciplinary action. The Board shall have the power to adopt a schedule of reasonable fines and penalties for violations of the terms of this Declaration, and for violations of any Rules adopted pursuant to section 5.2D. The penalties prescribed may include suspension of all rights and privileges of

membership; provided, however, that suspension for failure to pay Assessments shall be for a maximum period of thirty (30) days, renewable by the Board for an additional thirty (30) day period or periods until paid; and provided further that suspension for infraction of Rules or violation of this Declaration, other than for failure to pay Assessments, shall be limited to a maximum period of thirty (30) days per infraction or violation, and shall be imposed only after a hearing before the Board. The Board may extend that period for an additional thirty (30) day period or periods in the case of a continuing infraction or violation, and no hearing need be held for such extension. Written copies of Rules and the schedule of penalties shall be furnished to Owners. The Board shall levy fines and penalties and shall enforce such assessments as appropriate under applicable law.

**H. Enforcement:** The Board shall have the authority to enforce this Declaration as per section 9.1 hereof.

**I. Acquisition and Disposition of Property:** The Board shall have the power to acquire (by gift, purchase or otherwise), own, hold, improve, build upon, operate, maintain, convey, sell, lease, transfer, or otherwise dispose of real or personal property in connection with the affairs of the Association. Any transfer of property shall be by document signed or approved by two-thirds (2/3) of the total voting power of the Association.

**J. Loans:** The Board shall have the power to borrow money, and, only with the assent (by vote or written consent) of two-thirds (2/3) of the total voting power of the Association to Mortgage, pledge, deed in trust, or hypothecate any or all of its real or personal property as security for money borrowed or debts incurred.

**K. Dedication:** The Board shall have the power to dedicate all or any part of the Common Area to any public agency, authority, or utility for such purposes and subject to such conditions as may be agreed to by the Members. No such dedication shall be effective unless an instrument has been signed by two-thirds (2/3) of the Members of the Association agreeing to such dedication.

**L. Contracts:** The Board shall have the power to contract for goods and/or services for the Common Area(s), for the Condominiums, or for the Association, subject to limitations set forth in the Bylaws, or elsewhere in this Declaration. The Board shall not enter into any contracts with an independent contractor until it meets the requirements of section 8.1(3) herein.

**M. Delegation:** The Board and the officers of the Association shall have the power to delegate their authority and powers to committees, officers or employees of the Association, or to a manager employed by the Association, provided that the Board shall not delegate its responsibility:

(1) to make expenditures for capital additions or improvements chargeable against the reserve funds;

(2) to conduct hearings concerning compliance by an Owner or his or her tenant, lessee, guest or invitee with the Declaration, Bylaws or Rules promulgated by the Board;

(3) to make a decision to levy monetary fines, levy Reimbursement Charges, temporarily suspend an Owner's rights as a Member of the Association or otherwise impose discipline;

(4) to make a decision to levy Regular Assessments or Special Assessments; or

(5) to make a decision to bring suit, record a claim of lien or institute Foreclosure proceedings for default in payment of Assessments.

**N. Security:** The Board shall have the power (but not the obligation) to contract for security service for the Common Area. Notwithstanding the foregoing, if the Association elects to provide any security services or systems, neither the Association nor the Board shall be deemed to have made any representation or warranty to any Owner, nor the tenants or invitees of any Owner, nor to any other Person using the facilities or Improvements within the Project regarding security or safety. Each Owner shall be responsible for the security and safety of Persons who occupy or use the Condominium owned by the respective Owner. The Association shall not be subject to any claims or liability in connection with the provision of any security service or security system, or the failure to provide any security service or security system, within any portion of the Project.

**O. Appointment of Trustee:** The Board acting on behalf of the Association, has the power to appoint or designate a trustee to enforce Assessment Liens by sale as provided in section 4.9 and California Civil Code § 1367(b).

**P. Litigation/Arbitration:** The Board, subject to section 9.10 of this Declaration, shall have the power to institute, defend, settle or intervene in litigation, arbitration, mediation or administrative proceedings on behalf of the Association pursuant to Code of Civil Procedure § 383.

**Q. Other Powers:** In addition to the powers contained herein, the Board may exercise the powers granted to a nonprofit mutual benefit corporation under California Corporations Code § 7140.

**R. Common Area Improvements:** The Board shall have the authority and power to demolish, remove and reconstruct any and all improvements on or over or under the Common Area in a manner not inconsistent with this Declaration, and to construct, improve and repair improvements that are appropriate for the use and benefit of the Members of the Association, and to charge for the use of such improvements, provided that the Board shall not include in any Regular Assessment or Special Assessments the cost of any new Common Area improvement which exceeds \$25,000 in cost to be expended in any one calendar year, unless fifty-one percent (51%) or more of the voting power of the Association previously shall have approved said expenditure.

## ARTICLE VI UTILITIES

**6.1 Owners' Rights and Duties:** The rights and duties of the Owners of Condominiums within the Project with respect to sanitary sewer, storm sewer, water, drainage, electric, gas, television receiving, telephone equipment, cables and lines, meters, catch basins, storage tanks, wires, ducts, flues, pumps, pipes and exhaust flues, collectively, "Utility Facilities") shall be as follows:

**A.** Whenever Utility Facilities are installed within the Project, which Utility Facilities or any portion of those facilities lies in or upon Condominiums owned by other than the Owner of a Condominium served by those Utility Facilities, the Owners of any Condominium served by those Utility Facilities shall have the right of reasonable access for themselves or for utility companies to repair, replace and generally maintain those Utility Facilities as and when necessary, due to failure or inability of the Board to take timely action to make such repairs or perform such maintenance.

B. Whenever Utility Facilities serving more than one (1) Condominium are installed within the Project, the Owner of each Condominium served by those Utility Facilities shall be entitled to the full use and enjoyment of such portions of those Utility Facilities as service his or her Condominium.

C. In the event of a dispute between Owners with respect to the repair or rebuilding of Utility Facilities, or with respect to the sharing of the cost of those facilities, then, upon written request of one (1) Owner addressed to the other Owner(s), the matter shall be submitted first to the Board for mediation, and thereafter, if the dispute remains unresolved, to binding arbitration within sixty (60) days pursuant to the rules of the American Arbitration Association, or any successor rules, or to any other generally recognized system of alternative dispute resolution. The decision of the arbitrator(s) shall be final and conclusive on the parties, and judgment on the decision may be entered in any court having jurisdiction.

**6.2 Easements for Utilities and Maintenance:** Easements over, under and through the Project (including soffits and utility chases within Units, if any) for the installation, repair, and maintenance of electric, telephone, water, gas, and sanitary sewer lines and facilities, heating or air conditioning facilities, cable or master television antenna lines, drainage facilities, walkways, and landscaping as shown on the Map, and as may be hereafter required or needed to service the Project, exist in favor of the Association for the benefit of its Members.

**6.3 Association's Duties:** The Association shall maintain all Utility Facilities located in the Common Area except for those facilities maintained by utility companies, public, private, or municipal and those maintained by the Owners as described in section 7.22. The Association shall pay all charges for utilities supplied to the Project except those metered or charged separately to the Condominiums.

## ARTICLE VII USE RESTRICTIONS

In addition to all of the covenants contained herein, the use of the Project and each Condominium therein is subject to the following:

**7.1 Senior Citizen Housing Development:** All Units and buildings in the Project have been constructed as a "Senior Citizen Housing Development" as defined by California Civil Code section 51.3. All residents in the Project must be a "Qualifying Resident", meaning a person 55 years of age or older as specified in section 51.3(b)(1) of the California Civil Code or a "Qualified Permanent Resident" meaning a person who meets the requirements specified in sections 51.3(b)(2) or 51.3(b)(3) of the California Civil Code, or a "permitted health care resident" as specified in section 51.3(b)(7) of the California Civil Code. Temporary residency of a guest of a qualified permanent resident shall be permitted by a person less than 55 years of age for a period of time not more than 60 days in any year. A copy of Civil Code section 51.3 is attached hereto as Exhibit "C".

**7.2 Condominium Use:** No Condominium shall be occupied and used except for residential purposes by the Owners, their tenants, and social guests, and no trade or business shall be conducted therein, provided, however, that a Condominium may be used as a combined residence and executive or professional office by the Owner or occupant thereof, so long as such use does not interfere with the quiet enjoyment by other Condominium Owners of their Condominiums and does not include visiting clients. No tent, shack, trailer, garage, outbuilding or structure of a temporary character shall be used at any time as a residence, either temporarily or permanently.

Residents shall be limited as follows: No more than two (2) persons per bedroom in any Condominium shall be permitted as permanent residents. (A "permanent resident" means any

person residing in a Condominium more than sixty (60) days out of any twelve (12) consecutive month period.)

No health care facilities operating as a business or charity and serving the sick, elderly, disabled, handicapped or retarded shall be permitted in the Project.

No Condominium or any portion thereof in the Project shall be leased, subleased, occupied, rented, let, sublet, or used for or in connection with any time sharing agreement, plan, program or arrangement, including, without limitation, any so called "vacation license," "travel club," extended vacation," or other membership or time interval ownership arrangement. The term "time sharing" as used herein shall be deemed to include, but shall not be limited to, any agreement, plan, program, or arrangement under which the right to use, occupy or possess the Condominium or Condominiums, or any portion thereof in the Project rotates among various persons, either corporate, partnership, individual, or otherwise, on a periodically recurring basis for value exchanged, whether monetary or like kind use privileges, according to a fixed or floating interval or period of time of twenty-five (25) consecutive calendar days or less. Provided, this section shall not be construed to limit the personal use of any Unit or any portion thereof in the Project by any Unit Owner or his or her or its social or familial guests.

No yard sales are permitted, except for the option of one sale per calendar year, which date shall be designated by the Board, and in which all Owners shall have the opportunity to participate.

**7.3 Nuisances:** No noxious, illegal, or seriously offensive activities shall be carried on in any Condominium, or in any part of the Project, nor shall anything be done thereon which may be or may become a serious annoyance or a nuisance to or which may in any way interfere with the quiet enjoyment of each of the Owners' Condominiums or which shall in any way increase the rate of insurance for the Project, or cause any insurance policy to be cancelled or to cause a refusal to renew the same, or which will impair the structural integrity of any building.

**7.4 Permitted Vehicles and Parking:** Except as otherwise permitted in this section 7.3, only Permitted Vehicles shall be parked, stored or operated within the Project.

**A.** Permitted Vehicles shall mean appropriately licensed passenger automobiles, sports utility vehicles, motorcycles, and trucks having carrying capacity of 3/4 ton or less, vans having seating capacity of eight (8) persons or less. Owners and their tenants and invitees shall park their Permitted Vehicles only in the Garage Parking Spaces or designated surface parking spaces. Vehicles that are not Permitted Vehicles shall not be parked or stored in the Project. Except for commercial vehicles or construction equipment that are providing services to a Unit or the Association (but only during the period of time in which such services are being provided and subject to the Rules), Permitted Vehicles shall not include any commercial vehicle, construction equipment, trailer, camper, mobile home, recreational vehicle, truck having carrying capacity of greater than 3/4 ton, van having seating capacity in excess of eight (8) persons or any vehicle which is too large to fit within the Owner's garage, or covered carport, inoperable vehicles, boats or similar equipment. Vehicles that are otherwise Permitted Vehicles that are used both for business and personal use are not prohibited, provided that any signs or markings of a commercial nature on such vehicles shall be unobtrusive and inoffensive as determined by the Board. No excessively noisy or smoky vehicles shall be operated on the Project. No Owner or other occupant of any Unit shall park more than two (2) Permitted Vehicles within the Project at any one time.

**B.** No parking shall be permitted within the Common Area of the Project, except in designated parking spaces. All guest parking areas shall be used in accordance with the Rules of the Association.

C. The Association may install a sign at each vehicular entrance to the Project containing a statement that public parking is prohibited and that all vehicles not authorized to park on the Project will be removed at the owner's expense. The sign shall contain the telephone number of the local traffic law enforcement agency and shall not be less than 17 x 22 inches in size with lettering not less than one (1) inch in height.

D. The Association may cause the removal of any vehicle wrongfully parked on the Project, including a vehicle owned by an occupant of a Unit. If the identity of the registered owner of the vehicle is known or readily ascertainable, the President of the Association or his or her designee shall, within a reasonable time thereafter, notify the owner of the removal in writing by personal delivery or first-class mail. In addition, notice of the removal shall be given to the local traffic law enforcement agency immediately after the vehicle has been removed. The notice shall include a description of the vehicle, the license plate number and the address from where the vehicle was removed. If the identity of the owner is not known or readily ascertainable and the vehicle has not been returned to the owner within one hundred twenty (120) hours after its removal, the Association immediately shall send or cause to be sent a written report of the removal by mail to the California Department of Justice in Sacramento, California and shall file a copy of the notice with the proprietor of the public garage in which the vehicle is stored. The report shall be made on a form furnished by the Department of Justice and shall include a complete description of the vehicle, the date, time and place from which the vehicle was removed, the amount of mileage on the vehicle at the time of removal, the grounds for removal and the name of the garage or place where the vehicle is stored. Notwithstanding the foregoing, the Association may cause the removal, without notice, of any vehicle parked in a marked fire lane, within fifteen (15) feet of a fire hydrant, in a parking space designated for handicapped without proper authority or in a manner which interferes with any entrance to, or exit from, the Project or any Condominium, parking space or garage located thereon. The Association shall not be liable for any damages incurred by the vehicle owner because of the removal in compliance with this section or for any damage to the vehicle caused by the removal, unless such damage resulted from the intentional or negligent act of the Association or any person causing the removal of or removing the vehicle. If requested by the owner of the vehicle, the Association shall state the grounds for the removal of the vehicle.

E. Garage Parking Spaces shall not be converted into any use (such as a recreational room or storage room) that would prevent their use as parking space for the number of vehicles the space was designed to contain.

The provisions of this section 7.3 are intended to comply with Vehicle Code section 22658.2 in effect as of January 1, 2003. If this Vehicle Code section is amended, this provision automatically shall be amended in the same manner. If this section is repealed and no successor section is enacted, this provision shall remain in full force and effect. Vehicle Code section 22658.2 may have been amended by the State Legislature since this Declaration was recorded, and the Board should confirm the current statutory requirements.

**7.5 Signs:** Subject to Civil Code §§ 712, 713 and 1353.6, no signs shall be displayed to the public view on any Unit or on any other portion of the Project, except non-commercial signs may be displayed within a Unit that are approved by the Board or a committee appointed by the Board, that conform to the Rules regarding signs, and that conform to the requirements of State law, and applicable local ordinances. "For Sale" or "For Rent" signs shall be allowed to be displayed within areas of the Project that are designated in the Rules regarding such signs, and that conform to the requirements of State law, and applicable local ordinances, provided the design, dimensions and locations are reasonable. An Owner or his or her agent may display one (1) such For Sale or For Rent sign within his or her Unit and one sign in the Common Area advertising directions to the Owner's Unit which is for sale, rent, provided the design, dimensions (maximum 24 in. by 24 in.) and locations are reasonable and comply with the Rules regarding signs, and comply with the requirements of State law, and applicable local ordinances. These restrictions on display of signs



apply to signs that are visible from the exterior of a Unit, and are not intended to restrict signs that may be seen only from within the Unit in which the sign(s) is displayed.

**7.6 Animals:** Except as provided in this Declaration and permitted by the Rules, no animals of any kind shall be raised, bred, or kept in any Condominium, or on any other portion of the Project. Trained dogs used for assistance by visually impaired, hearing impaired or physically handicapped persons may be kept by an occupant or invitee of an Owner. Owners, their tenants or other occupants of Units may keep no more than two (2) usual and ordinary household pets such as a dog or cat, provided they are not kept, bred, or maintained for any commercial purposes. All pets shall be kept under reasonable control at all times. No pet shall be allowed in the Common Area except as may be permitted by Rules of the Board. No Owner shall allow his or her dog to enter the Common Area except on a leash. After making a reasonable attempt to notify the Owner, the Association or any Owner may cause any pet found within the Common Area in violation of the Rules of the Board or this Declaration to be removed by the Association (or any Owner) to a pound or animal shelter under the jurisdiction of the City of Menlo Park or County of San Mateo, by calling the appropriate authorities, whereupon the Owner may, upon payment of all expenses connected therewith, repossess the pet. Owners shall prevent their pet from soiling all portions of the Common Area and shall promptly clean up any mess left by their pets or their tenants. Owners shall be fully responsible for any damage caused by their pet. The Board, after notice and a hearing, may require the permanent removal of any animal that the Board determines to be a danger to the health and safety of any occupant in the Project, or otherwise to be a nuisance within the Project. The Board may find that an animal is a nuisance if the animal or its owner continue to violate the Rules regulating pets after receipt by the Owner of a written demand from the Board to comply with the Rules.

**7.7 Garbage and Refuse Disposal:** All rubbish, trash and garbage shall be regularly removed from the Project, and shall not be allowed to accumulate thereon. Trash, garbage and other waste shall only be kept in sanitary containers. All equipment for the storage or disposal of such materials shall be kept in a clean and sanitary condition. All equipment, garbage cans or recycling containers, woodpiles, or storage piles shall be kept screened and concealed from view of other Condominiums, streets and Common Areas, except when placed out for pick up on the designated garbage pick up day. The Association shall be responsible for removal of garbage from the central pick-up point(s). No toxic or hazardous materials shall be disposed of within the Project by dumping in the garbage containers or down the drains, or otherwise.

**7.8 Radio and Television Antennas:** No outside television antenna, microwave or satellite dish, aerial, or other such device (collectively "Antennas") with a diameter or diagonal measurement in excess of twenty-four inches (24") shall be erected, constructed or attached to any Common Area. Antennas with a diameter or diagonal measurement of twenty-four inches (24") or less may be installed only if they conform to the Rules. Reasonable restrictions which do not significantly increase the cost of the Antenna system or significantly decrease its efficiency or performance may be imposed. Antennas may not be attached to the exterior surface of any building or to any fence. The Board shall, in acting upon requests for approval of a satellite dish or other signal reception or transmission devices comply with California Civil Code §1376 and FCC [Federal Communications Commission] regulations.

**7.9 Right to Lease; Limitations on Leasing:**

A. Any Owner who wishes to lease his or her Condominium must meet each and every one of the following requirements, and the lease will be subject to these requirements whether they are included within the lease or not:

- (1) all leases must be in writing;

(2) the lease must be for the entire Unit and, not merely parts thereof, unless the Owner remains in occupancy;

(3) no lease shall be for a period of less than one (1) year;

(4) all leases shall be subject in all respects to provisions of the Declaration, the Bylaws, and all Rules adopted by the Board;

(5) all Owners who lease their Condominiums shall promptly notify the secretary of the Association in writing of the names of all tenants [and members of tenants' family] occupying such Condominiums and shall provide the Board with a complete copy of the lease; all Owners leasing their Condominium shall promptly notify the Board of the address and telephone number where such Owner can be reached;

B. Any failure of a tenant to comply with the Declaration, Bylaws, and Association Rules, shall be a default under the lease, regardless of whether the lease so provides. In the event of any such default, the Owner immediately shall take all actions to cure the default including, if necessary, eviction of the tenant;

C. If any tenant is in violation of the provisions of the Declaration, Bylaws, or Rules of the Association, the Association, may bring an action in its own name and/or in the name of the Owner to have the tenant evicted and/or to recover damages. If the court finds that the tenant is violating, or has violated any of the provisions of the Declaration, the Bylaws of the Association, or the Rules of the Association, the court may find the tenant guilty of unlawful detainer notwithstanding the fact that the Owner is not the plaintiff in the action and/or the tenant is not otherwise in violation of tenant's lease. For purposes of granting an unlawful detainer against the tenant, the court may assume that the Owner or person in whose name a contract (the lease or rental agreement) was made was acting for the benefit of the Association. The remedy provided by this subsection is not exclusive and is in addition to any other remedy or remedies which the Association has. If permitted by present or future law, the Association may recover all its costs, including court costs and reasonable attorneys' fees incurred in prosecuting the unlawful detainer action.

D. The Association shall give the tenant and the Owner notice in writing of the nature of the violation of the Declaration and/or Rules, and twenty-five (25) days from the mailing of the notice in which to cure the violation before the Association may file for eviction.

E. Each Owner shall provide a copy of the Declaration, Bylaws and all rules and regulations of the Association to each tenant of his or her Unit. By becoming a tenant, each tenant agrees to be bound by the Declaration, the Bylaws and the Rules of the Association, and recognizes and accepts the right and power of the Association to evict a tenant for any violation by the tenant of the Declaration, the Bylaws, and Rules of the Association. The Owner shall cause the tenant to acknowledge in writing that the tenant has read and understood the Declaration, the Bylaws, and the Rules, and agrees to comply with the provisions. The signed acknowledgement is to be provided to the Association's manager within fifteen (15) days of occupancy.

F. Notwithstanding anything to the contrary in this section 7.9, the following provisions shall control the leasing or rental of any Units in the Project:

(1) **Lease/Rental Units.** The purpose of this provision is to set forth the limitations and restrictions in regard to lease or rental of Units. The primary purpose of the limit and restrictions is to protect and preserve property values, the availability of preferred financing through compliance with secondary market standards for similar projects, the active participation and cooperation of the Members in the management of the Project by the Board of Directors, and

the residential nature and quality of the development by limiting the number of Units that are leased or rented to third parties.

**(2) Definitions.**

(a) "Lease" or "Rental" means any agreement between an Owner and a third party whereby the third party receives the use and possession of the Owner's Unit (without the Owner in residence) and the Owner receives monetary or other compensation in return for those rights.

(b) "Third Party" for the purposes of this section 7.9 means any party without an ownership interest in the Unit.

(c) "Quota" for purposes of this section 7.9 means the number of leased/rented Units at any point in time shall not be more than thirty (30) out of a total one hundred twenty-two (122) units.

(d) "Governing Documents" refers to the Declaration, as amended, the Association Bylaws, and any Association rules or policies currently in effect.

(e) "Owner" or "Owners" for purposes of this section 7.9 mean only the record holder(s) of fee simple legal title to a Unit in the Project, and shall not refer to any holder of a security of equitable interest in any Unit, including, without limitation, any purchaser under a contract of sale for any Unit.

**(3) Rights of Owners.** Any Owner shall be entitled to rent/lease his/her Unit only where one or more of the following circumstances exist.

(a) The Unit is leased to a tenant prior to the date of recordation of this Amended Declaration (provided this exemption shall cease as to a particular Unit upon the expiration of the lease, including any extensions provided for therein, in place as of the date of recordation of this Declaration); or

(b) The Owner became Owner of the subject Unit prior to the effective date of this Amended Declaration and the lease is executed thereafter and complies with the provisions of section 7.9(4)(b), below; or

(c) The Owner inherited the subject Unit as a bona fide heir to the estate of a deceased Owner described in subpart (2) above and the lease is executed thereafter and complies with the provisions of section 7.9(4)(b), below; or

(d) The Board of Directors has formally approved, in writing, the Owner's written request to lease/rent the subject Unit pursuant to section 7.9(5)(a): (b) or (c); or

(e) The Board of Directors has waived its right to deny an Owner's written request to rent/lease a Unit by failing to make a determination within the time periods provided for in section 7.9(4), below.

**(4) Request for Approval of Board.** All Owners leasing or renting at the time this provision becomes effective must "register" with the Board, by providing a copy of the existing lease. Existing lease agreements on the date of recordation of this Declaration shall be deemed approved, but not be extended beyond the term provided in such lease agreement, including any extensions provided for therein, without compliance with this section 7.9(4). All other Owners must seek approval prior to entering into a lease or rental arrangement Owners applying for

approval of leasing of a Unit have the right to request a hearing before the Board of Directors. The hearing shall be set before the Board of Directors within thirty (30) days after receipt of the request for hearing together with the application for approval, and the Board shall make its determination within five (5) days after the hearing. In cases where a hearing is not requested, the Board shall make its determination within thirty (30) days after receipt of the application for approval. If the Board fails to make a determination on any application within the foregoing time periods, its right to disapprove the request is waived. These time limits may be extended by the written agreement of both parties, i.e., the Owner(s) and Board of Directors. The Board of Directors has the power to approve or disapprove requests to rent/lease Units, in accordance with the standards set forth in section 7.9(5), below. Before any Unit may be considered for approval to be leased/rented, and before any of the foregoing time periods begin to run, the Owner must provide the Board of Directors with all of the following documents for its consideration.

(a) A written request to lease/rent the subject Unit, identifying the subject Unit and stating the proposed lease term and the tenant and other information required in this section 7.9; and

(b) A written lease (in the form to be used by the Owner) which specifies the following terms and conditions:

(i) The tenant shall be subject to all of the same provisions of the Governing Documents as the Owner;

(ii) Failure by the tenant to comply with the provisions of the Governing Documents will constitute a default under the rental/lease agreement; and

(iii) The term shall not be less than one (1) year; and

(c) A "Statement of Hardship and Request for Board Hearing" setting forth the special circumstances for the request to lease the Unit, if the Owner wishes to qualify for approval under section 7.9(5)(c).

The foregoing written applications and supporting documents (the "Completed Application") must be hand-delivered personally to a Board member at a Board meeting or hand-delivered or mailed to the attention of the President of the Board of Directors. Notwithstanding anything to the contrary in this section 7.9, the Board of Directors has discretion to deny consideration of a request where a Completed Application has not been received by the Board.

**(5) Criteria for Approval.** The Board of Directors shall follow the criteria set forth in this section 7.9 in considering applications for approval to lease/rent Units.

**(a) Required Approval of Lease Application.** The Board of Directors shall approve any requests to lease a Unit so long as the requirements of this section 7.9 have been satisfied, and (a) the present number of leased/rented Units in the Project does not exceed the "Quota" set forth in section 7.9(2)(c) above; or (b) the Owner is an Owner qualified under sections 7.9(3)(a), 7.9(3)(b) or 7.9(3)(c) above; or (c) the Board finds that the criteria set forth in section 7.9(5)(c) have been met.

**(b) Required Disapproval of Lease Application.** The Board of Directors shall not approve any requests to lease/rent a Unit where the requirements of subpart (1), above, have not been met.

**(c) Approval of Lease Application in Special Cases.**

(i) The Board shall approve the temporary leasing of a Unit for a one (1) year period WITHOUT regard to the Quota limitation in special circumstances which the Board finds meet the following criteria:

(A) non-permanent job transfer, where the Owner is moving out of the area because of the distance of new work site from the Project and expects to occupy the Unit again at the end of the assignment;

(B) serious illness in the family or a person with a close relationship to the Owner which requires the Owner to live elsewhere temporarily to provide care for the ill person;

(C) substantial, adverse changes in the Owner's financial condition, due to job loss, emergency expenses or other sudden loss, which create a significant problem for the Owner in maintaining the expenses of ownership of the Unit without the benefit of rental income and threaten forfeiture of the Unit; and

(D) the Owner has actively tried to sell the Unit by listing the Unit for sale on the local multiple listing at a reasonable price for three consecutive months without receiving an offer to buy the Unit at a price within five percent (5%) of the listing price (a reasonable price shall be a price within \$20,000 of the highest sales price of comparable Units within the Project within the six (6) month period preceding the listing of the Unit for sale, or if no such sales exist, the appraised value of the Unit based on a letter appraisal from a local realtor with at least five (5) years experience in residential sales in the local area, to be obtained by the Association);

(ii) The Board may also approve the temporary leasing of a Unit for a one (1) year period WITHOUT regard to Quota limitation in other special circumstances where the liability to lease the Unit will create a serious hardship on the Owner as a result of unexpected circumstances.

The purpose of this section 7.9(5)(c) is to protect Owners from serious hardship, but it is not intended to permit owner-occupied Units to be converted to rental Units at a time that the Quota has been exceeded unless the Owner shows one or more of the special circumstances set forth in section 7.9(5)(c)(i), above, or other serious hardship due to unexpected circumstances. Any denial of a "Special Circumstances" request must be based on a finding by the Board of Directors that withholding its approval is reasonably related to the protection, preservation or proper operation of the Project and the purposes of the Association as set forth in section 7.9(5)(c), above, or otherwise in its Governing Documents, and that the Owner will not suffer serious hardship due to unexpected circumstances. For purposes of this section 7.9(5)(c), not having read or known the content of this Declaration is not an "unexpected circumstance." An Owner may be considered for an extension to the one-year period referred to in this section 7.9(5)(c) by reapplying to the Board of Directors for approval to lease the Unit as provided in this section 7.9.

**(6) Record Keeping/Waiting List.**

**(a) Association's Obligations.** The Secretary or other designated representative of the Association shall:

(i) Keep records regarding the number of leased/rented Units;

(ii) Keep records regarding mailing address and telephone number of the Owner and telephone number of the tenant, as provided by the Owners;

(iii) Keep records of all requests to lease/rent Units and files containing the date of request and lease agreements provided by the Owners;

(iv) Keep a waiting list of all Owners desiring to lease/rent their Units when the Quota limitations are filled. Owners shall receive priority on the waiting list according to the order in which their requests to lease/rent their Units are received. Once a waiting list is formed, requests of Owner on that list will be considered before those requests of Owners not on the list, in order of priority, except as to section 7.9(5)(c)(i) and (ii) special cases above.

**7.10 Architectural Control:** The purpose and intent of this section is to empower the Association to preserve property values within the Project. The Board shall operate pursuant to the following guidelines:

**A.** The emphasis shall be upon keeping out of the Project what is considered bizarre, outlandish, or offensive to a reasonably prudent homeowner within the Project. The objective then becomes to prevent additions, alterations or replacements which are reasonably likely to be detrimental to the overall ambiance of the Project, and reasonably likely to adversely affect property values throughout the Project. The restrictions are not intended to empower the Board to act arbitrarily, capriciously, or whimsically in the process of reviewing plans. Standards should be established which are both reasonable and objective, and which are reasonably ascertainable, and are uniformly and fairly applied to all, and in all cases. The Board shall base its decisions on what is in the best interests of the Project as a whole, and not upon what will appease a particular Member or group of Members.

**B.** No building, fence, wall, pool, spa, obstruction, outside or exterior wiring, balcony, screen, patio, patio cover, tent, awning, carport, carport cover, improvement or structure of any kind shall be commenced, installed, erected, painted, repainted or maintained upon the Project, nor shall any alteration or improvement of any kind be made thereto until the same has been approved in writing by the Board. Notwithstanding the foregoing, Owners may improve or alter any improvements within the interior boundaries of the Owner's Unit, provided such improvement or alteration does not impair the structural or acoustical integrity of any Common Area, the utilities or other systems servicing the Common Area or other Condominiums, and does not involve altering any Common Area (including bearing walls).

**C.** Plans and specifications showing the nature, kind, shape, color, size, materials and location of any proposed improvements or alterations, shall be submitted to the Board for approval as to quality of workmanship and design and harmony of external design with existing structures. No permission or approval shall be required to repaint in accordance with the original color scheme, or to rebuild in accordance with Declarant's original plans and specifications. No permission or approval shall be required to repaint in accordance with a color scheme previously approved by the Board, or to rebuild in accordance with plans and specifications previously approved by the Board. Nothing contained in this paragraph shall be construed to limit the right of an Owner to paint the interior of his or her Unit any color desired.

**D.** No landscaping or other physical improvements or additions shall be made to any decks, balconies, planter boxes, patios or yards which are visible from the street or from the Common Area until plans and specifications showing the nature, kind, shape and location of the materials shall have been submitted to and approved in writing by the Board.

In reviewing and approving or disapproving a proposed alteration, modification or improvements to a Unit that is subject to review under section 7.10 of the Declaration, the Board or Architectural Committee shall satisfy the following requirements in accordance with California Civil Code section 1378:

(1) The Board or Architectural Committee shall provide a fair, reasonable, and expeditious procedure for making its decision. The procedure shall provide for prompt deadlines. The procedure shall state the maximum time for response to an application or a request for reconsideration by the Board of Directors.

(2) A decision on a proposed change shall be made in good faith and may not be unreasonable, arbitrary, or capricious.

(3) A decision on a proposed change shall be consistent with any governing provision of law, including, but not limited to, the Fair Employment and Housing Act (Part 2.8, commencing with Section 12900) of Division 3 of Title 2 of the Government Code.

(4) A decision on a proposed change shall be in writing. If a proposed change is disapproved, the written decision shall include both an explanation of why the proposed change is disapproved and a description of the procedure for reconsideration of the decision by the Board of Directors.

(5) If a proposed change is disapproved, the applicant is entitled to reconsideration by the Board of Directors that made the decision at an open meeting of the Board. This paragraph does not require reconsideration of a decision that is made by the Board or a body that has the same membership as the Board, at a meeting that satisfies the requirements of California Civil Code section 1363.05. Reconsideration by the Board does not constitute dispute resolution within the meaning of California Civil Code section 1363.820.

E. In the event the Board fails to approve or disapprove plans and specifications in writing within thirty (30) days after the same have been submitted to it, approval will not be required and the related covenants shall be deemed to have been fully complied with.

F. Approval of plans by the Board shall in no way make the Board or its members responsible for or liable for the improvements built after approval of the plans, and the Owner whose plans are approved shall defend, indemnify and hold the Board, the Association, and its members, harmless from any and all liability arising out of such approval.

**G. Governmental Approvals:** All alterations, modifications, or other improvements on or within Units in the Project shall comply with all design requirements, approvals and procedures of the City. Before commencement of any alteration or improvements approved by the Board, the Owner shall comply with all appropriate governmental laws and regulations. Approval by the Board does not satisfy the appropriate approvals that may be required by any governmental entity with appropriate jurisdiction.

**H. Completion of Work; Review of Work:** Upon approval of the Board, the Owner shall diligently proceed with the commencement and completion of all work so approved by the Board in compliance with the approvals granted. The work must be commenced within thirty (30) days from the date of approval unless the Board permits the work to be commenced at a later time. If the work is not commenced within six months after the approval date, or such later time as

the Board has granted, then the approval shall be deemed cancelled, and the Owner must reapply to the Board before undertaking any such work.

The Board shall inspect work within thirty (30) days after a notice of completion has been delivered to the Board by the Owner. The Board may also inspect the work at any time prior to completion as it deems appropriate to determine that the Board approval is being followed. The Board is to inspect the work performed, and determine whether it was performed and completed in compliance of the approval granted in all material respects. If at any time during the construction of any work, the Board finds that the work was not performed or completed in compliance of the approval granted in all material respects, or if the Board finds that the appropriate approval which was required for any work was not obtained, the Board shall notify the Owner in writing of the non-compliance. The notice shall specify in writing the particulars of non-compliance, and shall set forth the requirement of the Owner to remedy the non-compliance. The Board shall determine in its reasonable judgment whether an alteration, modification or improvement complies with the approval as granted in material respects. Minor changes, deviations or imperfections that do not negatively affect or impact the Project shall not be considered as non-compliance.

If the Board has determined an Owner has not constructed an improvement in compliance of the approval granted in all material respects, and if the Owner fails to remedy such non-compliance in accordance with provisions of the notice of non-compliance, then after expiration of 30 days from the date of such notification, the Board shall provide Notice and Hearing to consider the Owner's continuing non-compliance. The Board shall act after expiration of 30 days from the date of such notification. At the Hearing, if the Board finds that there is no valid reason for the continuing non-compliance, the Board shall then require the Owner to remedy the non-compliance as necessary and appropriate in the determination of the Board as to result in the improvement being rendered as reasonably in compliance as is appropriate for the overall good and benefit of the Project, or remove the same within a period of not more than 45 days from the date of the Board's determination. If the Owner does not comply with the Board's ruling within such period, or within any extension of such period as the Board, in its discretion may grant, the Board may (1) remove the non-complying improvement, (2) remedy the non-compliance, (3) institute legal proceedings to enforce compliance or completion.

**7.11 Structural Integrity:** Nothing shall be done in or on any Unit or in or on the Common Area which will impair the structural integrity of the building. Planters or pots heavier than fifty (50) pounds (dry weight) and a maximum of 8 15-gallon containers are not to be placed on decks or balconies.

**7.12 Clothes Lines:** There shall be no outside laundering or drying of clothes. No draping of towels, carpets, flags, or laundry over railings shall be allowed.

**7.13 Power Equipment and Motor Vehicle Maintenance:** No power equipment, hobby shops, or motor vehicle maintenance (other than emergency work) shall be permitted on the Project except with prior written approval of the Board. Use of power tools is restricted to the hours of 8:00 a.m. to 5:00 p.m. on weekdays and Saturdays. Approval shall not be unreasonably withheld and in deciding whether to grant approval the Board shall consider the effects of noise, air pollution, dirt or grease, fire hazard, interference with radio or television reception, and similar objections. All hazardous or toxic materials shall be disposed of properly by each Owner.

**7.14 Liability of Owners for Damage to Common Area:** The Owner of each Condominium shall be liable to the Association for all damage to the Common Area or improvements to the extent described in section 5.1A.

**7.15 Activities Causing Increase in Insurance Rates:** Nothing shall be done or kept on any Unit or in any improvements constructed thereon or in the Common Area, which will



increase any applicable rate of insurance or which will result in the cancellation of insurance on any Unit or any part of the Common Area, or which would be in violation of any law.

**7.16 Flags, Pennants, Banners, Etc.:** There shall be no exhibiting, flying or hanging of any flags, pennants, banners, kites, towels, etc., from any area of the Project that would be visible from the street, Common Area, or the other Units, except in conformance with Rules adopted by the Board, and for flags that are expressly permitted by statute.

**7.17 Floor Coverings:** No change in the floor covering materials originally installed in the Units shall be permitted except with the consent of the Board. To reduce sound transmission, all Units which are above other Units shall have all floor areas except kitchens and bathrooms covered with carpet or other material which provides equivalent insulation against sound transmission to the Unit below. There shall be no alteration of floor coverings that will result in an increase in sound transmission into any other Unit.

**7.18 Window Coverings:** All drapes, curtains, shutters, blinds or other window coverings visible from the street or Common Areas shall be beige, white, or off-white in color or lined in beige, white, or off-white, or as the case may be, of colors, materials and patterns which are approved by the Board.

**7.19 Sports Apparatus:** No sports apparatus shall be attached to the building exterior, or affixed to any portion of the Common Area nor shall any portable apparatus be used for playing sports in the Project.

**7.20 Common Area Use:** Nothing shall be stored, grown, or displayed in the Common Area, including parking spaces, decks, balconies and patios, that is not approved in advance by the Board. No motor vehicle mechanical maintenance is permitted in the Common Area.

**7.21 Keys and Locks:** The Board shall retain a pass key to each Unit. No Owner shall alter any lock or install a new or additional lock in any door providing access to his or her Unit or any portion of the Common Area (except storage lockers inside of a storage room) over which he or she has exclusive use, without the consent of the Board. In the interest of security, safety, and welfare of the membership, Board of Directors retain the right to re-key all units when necessary.

**7.22 Owner's Right and Obligation to Maintain and Repair:** Except for those portions of the Project which the Association is required to maintain and repair, each Condominium Owner shall, at his or her sole cost and expense, maintain and repair the Unit, keeping the same in good condition. Each Owner shall be responsible for and bear the cost of maintenance, repair and replacement of the following items within such Owner's Unit: interior surfaces of all perimeter and interior walls, ceilings and floors (including carpeting, tile, wall paper, paint or other covering); garbage disposals, hot water heaters, ranges, refrigerators, dishwashers, washing machines, dryers, light fixtures, smoke detectors, and any and all other appliances of any nature whatsoever; heating, ventilating and air conditioning equipment servicing such Unit (although such equipment may be located in part outside such Unit); exterior door hardware, gaskets and seals, interior doors, including all hardware on the doors; cabinets, light bulbs; plumbing and other fixtures of any nature whatsoever; "built-in" features; and decorative features, fireplaces, if any, and any furniture and furnishings. Each Owner shall maintain, repair and replace any smoke detectors located in the Owner's Unit. Each Owner shall keep the Restricted Common Area appurtenant to the Owner's Condominium in a clean and neat condition at all times. Each Owner shall have the exclusive right to paint, plaster, panel, tile, wax, paper or otherwise refinish and decorate the inner surfaces of the walls, ceilings, floors, and doors bounding his or her Unit. In the event an Owner fails to maintain the interior of his or her Unit in a manner which the Board deems necessary to preserve the appearance and value of the Project, the Board may notify Owner of the work required and request it

be done within sixty (60) days from the giving of such notice. Use of chemicals that may damage the drain pipes and fixtures is strictly forbidden.

In order to reduce the presence of mold, fungi, spores, pollens and other botanical substances, or other allergens (collectively "Mold") within the Unit, the Owners shall inspect the interior of their dwellings not less frequently than once each quarter to check for water leaks or other breaches of the watertight integrity of the improvements, and for the presence of Mold. If any water leaks and/or Mold are detected within the Unit, the Owner shall immediately take appropriate corrective steps to repair the leak, and/or remove the Mold and to maintain proper ventilation within enclosed areas, and to maintain humidity levels to reduce the risk of Mold growth, and take such other prudent steps as may be appropriate to prevent Mold growth, or eliminate any existing Mold. Any mold or other infestation detected shall be noted to the Board in writing for appropriate action.

In the event the Owner fails to carry out such maintenance within one week, the Board may, following notice and hearing as provided in the Bylaws, cause such work to be done and the cost of the work shall immediately be paid by such Owner to the Association as a Reimbursement Charge, and until paid shall bear interest at the rate of twelve percent (12%) per annum (but no greater than the maximum rate authorized by law).

## ARTICLE VIII INSURANCE; DAMAGE OR DESTRUCTION; CONDEMNATION

**8.1 Insurance:** The Association shall obtain and maintain the following insurance:

(1) a master hazard policy insuring all improvements, equipment and fixtures in the Project (including the Units as originally constructed) with policy limits of either: [a] full replacement value of the covered improvements or [b] no less than 80% of replacement cost of the covered improvements, excluding foundations and footings in either instances, unless otherwise required by FNMA or FHLMC requirements as set forth in subparagraph 8.1A, below. The following endorsements should be included in any such master hazard policy, if commercially reasonable to obtain:

- (a) changes in building codes ("ordinance or law endorsement");
- (b) inflation guard coverage;
- (c) demolition coverage;
- (d) "agreed-amount" endorsement (to eliminate a coinsurance problem);
- (e) replacement cost endorsement; and
- (f) primary coverage endorsement.

(2) an occurrence version comprehensive general liability policy insuring the Association, its agents, the Owners and their respective family members, against liability incident to the ownership or use of the Common Area or any other Association owned or maintained real or personal property. The amount of general liability insurance that the Association shall carry at all times shall be not less than the minimum amounts required by California Civil Code §1365.7 and § 1365.9;

(3) workers' compensation insurance to the extent required by law (or such greater amount as the Board deems necessary). The Association shall obtain a Certificate of Insurance naming it as an additional insured in regard to workers' compensation claims from any independent contractor who performs any service for the Association, if the receipt of such a certificate is practicable;

(4) fidelity bonds or insurance covering officers, directors, and employees that have access to any Association funds;

(5) officers and directors liability insurance in the minimum amounts required by California Civil Code §§ 1365.7;

(6) insurance against water damage, and liability for non-owned and hired automobiles, such other insurance as the Board in its discretion considers necessary or advisable; and

(7) earthquake insurance to the extent required by law, and if not required by law, then to the extent available at commercially reasonable rates in the opinion of the Board.

**A. Amount, Term and Coverage.** The amount, term and coverage of any policy required hereunder (including the type of endorsements, the amount of the deductible, the named insureds, the loss payees, standard Mortgage clauses, notices of changes or cancellations, and the insurance company rating) shall satisfy the minimum requirements imposed for this type of project by the Federal National Mortgage Association ("FNMA") and the Federal Home Loan Mortgage Corporation ("FHLMC") or any successor to either of those entities (except for earthquake insurance, the purchase of which shall be within the discretion of the Board, as provided in § 8.1(7) above). If the FNMA or FHLMC requirements conflict, the more stringent requirement shall be met. If FNMA and FHLMC do not impose requirements on any policy required hereunder, the term, amount and coverage of such policy shall be no less than that which is customary for similar policies on similar projects in the area. The Board shall adopt a policy regarding payment of deductibles on any insurance coverage. Unless the Board determines otherwise, the Association shall pay deductibles required under any insurance claims from Association funds, unless insufficient funds are available to the Association from the Association's accounts or from funds borrowed by the Association in accordance with this Declaration, in which event the Association shall levy a Special Assessment, in accordance with sections 4.3B and 4.4 of this Declaration, with respect to the amount of any such deductible which exceeds funds available to the Association from Association funds or from borrowing.

**B. Representation for Claims.** Each Owner appoints the Association or any insurance trustee designated by the Association to act on behalf of the Owners in connection with all insurance matters arising from any insurance policy maintained by the Association, including without limitation, representing the Owners in any proceeding, negotiation, settlement or agreement.

**C. Waiver of Subrogation.** Any insurance maintained by the Association shall contain "waiver of subrogation" as to the Association and its officers, directors and Members, the Owners and occupants of the Condominiums and Mortgagees, and, if obtainable, a cross-liability or severability of interest endorsement insuring each insured against liability to each other insured.

All individually owned insurance shall contain a waiver of subrogation as to the Association and its officers, directors and Members, the Owners and occupants of the Condominiums and Mortgagees, and all Members are deemed to have waived subrogation rights as to the Association and/or other Members, whether or not their policies so provide.

**D. Review of Policies.** The Association shall periodically (and not less than once every three (3) years) review all insurance policies maintained by the Association to determine the adequacy of the coverage and to adjust the policies accordingly.

**E. Separate Insurance Limitations.** No Owner shall separately insure his or her Condominium against loss by fire or other casualty covered by any insurance carried by the Association. If any Owner violates this provision, any diminution in insurance proceeds otherwise payable under the Association's policies that results from the existence of such other insurance will be chargeable to the Owner who acquired other insurance. The insurance maintained by the

Association does not cover the personal property in the residences and does not cover personal liability for damages or injuries occurring in the Units. Owners shall insure their personal property against loss and shall carry personal liability insurance. In addition, any improvements made by an Owner within his or her Unit shall be separately insured by the Owner. The insurance shall be the type of coverage commonly known as "improvements insurance" (commonly referred to as "HO-6 coverage"). The Owner shall not obtain such insurance if the policy referred to in section 8.1(1) will provide coverage for such improvements. Tenants shall carry tenants' contents insurance (commonly referred to as "HO-4 coverage").

**F. Copies of Policies; Notice to Members.** The Association shall make available to all Members a copy of the Association's policy to enable Members to insure their Units without duplicating insurance carried by the Association and inadvertently triggering a co-insurance clause in the Association's policy referred to in section 8.1(1). The Association shall distribute annually to the Members a summary of the Association's insurance policies as required by Civil Code section 1365(e) and as provided in the Bylaws. The Association, as soon as reasonably practical, shall notify its Members by first-class mail if any of the policies have been cancelled and not immediately renewed or restored or if there is a significant change such as a reduction in coverage or limits or an increase in the deductible for any policy. If the Association receives any notice of non-renewal of a policy, the Association immediately shall notify its Members if replacement coverage will not be in effect by the date the existing coverage will lapse.

To the extent that the information required to be disclosed, as described in Civil Code §1365(e), is specified in the insurance policy declaration page, the Association may meet its disclosure obligations by making copies of that page and distributing copies to all its Members.

**G. Limitation on Liability.** The Association, and its directors and officers, shall have no liability to any Owner or Mortgagee if, after a good faith effort, it is unable to obtain the insurance required hereunder, because the insurance is no longer available or, if available, can be obtained only at a cost that the Board in its sole discretion determines is unreasonable under the circumstances, or the Members fail to approve any Assessment increase needed to fund the insurance premiums. In such event, the Board immediately shall notify each Member and any Mortgagee entitled to notice that the insurance will not be obtained or renewed.

**H. Policies and Procedures Regarding the Filing and Processing of Claims:** The Board shall adopt a policies and procedures regarding the filing and processing of claims for damage and destruction of Common Area improvements or any other matters covered by insurance maintained by the Association.

**8.2 Damage or Destruction:** If Project improvements are damaged or destroyed by fire or other casualty, the improvements shall be repaired or reconstructed substantially in accordance with the original as-built plans and specifications, modified as may be required by applicable building codes and regulations in force at the time of such repair or reconstruction and subject to such alterations or upgrades as may be approved by the Board, unless either of the following occurs: (1) the cost of repair or reconstruction is more than fifty percent (50%) of the current replacement costs of all Project improvements, available insurance proceeds are not sufficient to pay for at least eighty-five percent (85%) of the cost of such repairs or reconstruction, and three-fourths (3/4) of the total voting power of the Association residing in Members and their First Lenders vote against such repair and reconstruction; or (2) available insurance proceeds are not sufficient to substantially repair or reconstruct the improvements within a reasonable time as determined by the Board, a Special Assessment levied to supplement the insurance fails to receive the requisite approval (if such approval is required) as provided in section 4.4, and the Board, without the requirement of approval by the Owners, is unable to supplement the insurance by borrowing on behalf of the Association sufficient monies to enable the improvements to be substantially repaired or reconstructed within a reasonable time.

**A. Process For Repair or Reconstruction:** If the improvement is to be repaired or reconstructed and the cost for repair or reconstruction is in excess of twenty-five percent (25%) of the current replacement cost of all the Project improvements, the Board shall designate a construction consultant, a general contractor, and an architect for the repair or reconstruction. All insurance proceeds, Association monies allocated for the repair or reconstruction, and any borrowings by the Association for the repair or reconstruction shall be deposited with a commercial lending institution experienced in the disbursement of construction loan funds (the "depository") as selected by the Board. Funds shall be disbursed in accordance with the normal construction loan practices of the depository that require as a minimum that the construction consultant, general contractor and architect certify within ten (10) days prior to any disbursement substantially the following:

(1) that all of the work completed as of the date of such request for disbursement has been done in compliance with the approved plans and specifications;

(2) that such disbursement request represents monies which either have been paid by or on behalf of the construction consultant, the general contractor or the architect and/or are justly due to contractors, subcontractors, materialmen, engineers, or other persons (whose name and address shall be stated) who have rendered or furnished certain services or materials for the work and giving a brief description of such services and materials and the principal subdivisions or categories thereof and the respective amounts paid or due to each of said persons in respect thereof and stating the progress of the work up to the date of said certificate;

(3) that the sum then requested to be disbursed plus all sums previously disbursed does not exceed the cost of the work insofar as actually accomplished up to the date of such certificate;

(4) that no part of the cost of the services and materials described in the foregoing paragraph 8.2(1) has been or is being made the basis for the disbursement of any funds in any previous or then pending application; and

(5) that the amount held by the depository, after payment of the amount requested in the pending disbursement request, will be sufficient to pay in full the costs necessary to complete the repair or reconstruction.

If the cost of repair or reconstruction is less than twenty-five percent (25%) of the current replacement cost of all the Project improvements, the Board shall disburse the available funds for the repair and reconstruction under such procedures as the Board deems appropriate under the circumstances.

The repair or reconstruction shall commence as soon as reasonably practicable after the date of such damage or destruction and shall be completed as quickly as is reasonably practicable after commencement of reconstruction, subject to delays that are beyond the control of the party responsible for making the repairs. The Owner of the damaged or destroyed improvement immediately shall take such steps as may be reasonably necessary to secure any hazardous condition and to screen any unsightly views resulting from the damage or destruction.

**B. Process If Repair or Reconstruction Not Undertaken:** If the improvements are not repaired or reconstructed in accordance with the foregoing, all available insurance proceeds shall be disbursed among the Owners of the damaged Units and their respective Mortgagees in proportion to the respective fair market values of their Condominiums as of the date immediately preceding the date of damage or destruction as determined by a qualified independent appraiser selected by the Board, after first applying the proceeds to the cost of

mitigating hazardous conditions on the Project, making provision for the continuance of public liability insurance to protect the interests of the Owners until the Project can be sold, and complying with all other applicable requirements of governmental agencies. In the event of a failure to agree upon an appraiser, the appraiser shall be appointed by the then President of the San Mateo County Bar Association.

If the failure to repair or reconstruct results in a material alteration of the use of the Project from its use immediately preceding the damage or destruction as determined by the Board (a material alteration shall be conclusively presumed if repair or reconstruction costs exceed twenty-five percent (25%) of the current replacement cost of all Project improvements), the Project shall be sold in its entirety under such terms and conditions as the Board deems appropriate. If any Owner or First Lender disputes the Board's determination as to a material alteration, the dispute shall be submitted to arbitration pursuant to the rules of the American Arbitration Association, and the decision of the arbitrator shall be conclusive and binding on all Owners and their Mortgagees.

If the Project is sold, the sales proceeds shall be distributed to all Owners and their respective Mortgagees in proportion to their respective fair market values of their Condominiums as of the date immediately preceding the date of damage or destruction as determined by the independent appraisal procedure described above. For the purpose of effecting a sale under this section 8.2, each Owner grants to the Association an irrevocable power of attorney to sell the entire Project for the benefit of the Owners, to terminate the Declaration and to dissolve the Association. In the event the Association fails to take the necessary steps to sell the entire Project as required hereunder within sixty (60) days following the date of a determination by the Board or arbitrator of a material alteration, or if within one hundred twenty (120) days following the date of damage or destruction the Board has failed to make a determination as to a material alteration, any Owner may file a partition action as to the entire Project under California Civil Code §1359, or any successor statute, and the court shall order partition by sale of the entire Project and distribution of the sale proceeds as provided herein.

Notwithstanding anything herein to the contrary, any Owner or group of Owners shall have a right of first refusal to match the terms and conditions of any offer made to the Association in the event of a sale of the Project under this section 8.2 B, provided this right is exercised within ten (10) days of receipt by the Owners of a notice from the Association containing the terms and conditions of any offer it has received. If the Owner or group of Owners subsequently default on their offer to purchase, they shall be liable to the other Owners and their respective Mortgagees for any damages resulting from the default. If more than one (1) Owner or group elects to exercise this right, the Board shall accept the offer that in its determination is the best offer.

**8.3 Condemnation:** The Association shall represent the Owners in any condemnation proceedings or in negotiations, settlements and agreements with the condemning authority for acquisition of the Common Area(s), or part thereof. In the event of a taking or acquisition of part or all of the Common Area(s) by a condemning authority, the award or proceeds of settlement shall be payable to the Association, or any trustee appointed by the Association, for the use and benefit of the Owners and their Mortgagees as their interests may appear. In the event of an award for the taking of any Condominium in the Project by eminent domain, the Owner of such Condominium shall be entitled to receive the award for such taking and after acceptance thereof he or she and his or her Mortgagee shall be divested of all interest in the Project if such Owner shall vacate his or her Condominium as a result of such taking. The remaining Owners shall decide by majority vote whether to rebuild or repair the Project, or take other action. The remaining portion of the Project shall be resurveyed, if necessary, and the Declaration shall be amended to reflect such taking and to readjust proportionately the percentages of undivided interest of the remaining Owners in the Project. In the event of a taking by eminent domain of any part of the Common Area, the Association shall participate in the negotiations, and shall propose the method of division of the proceeds of condemnation, where Condominiums are not valued separately by the condemning

authority or by the court. Proceeds of condemnation shall be distributed among Owners of Condominiums and their respective Mortgagees according to the relative values of the Condominiums affected by the condemnation, said values to be determined by the method provided in section 8.2.

If there is a substantial taking of the Project (more than fifty percent (50%)), the Owners may terminate the legal status of the Project and, if necessary, bring a partition action under California Civil Code §1359 or any successor statute, on the election to terminate by fifty-one percent (51%) of the total voting power of the Association and the approval of Eligible Mortgage Holders holding Mortgages on Condominiums which have at least fifty-one percent (51%) of the votes of Condominiums subject to Eligible Mortgages. The proceeds from the partition sale shall be distributed to the Owners and their respective Mortgagees in proportion to the fair market values of their Condominiums as determined under the method described in section 8.1.

## ARTICLE IX GENERAL PROVISIONS

**9.1 Enforcement:** The Association, or any Owner, shall have the right to enforce, by any proceeding at law or in equity, all restrictions, conditions, covenants, reservations, liens, and charges now or hereafter imposed by the provisions of this Declaration, the Articles and the Bylaws, and in such action shall be entitled to recover reasonable attorneys' fees as are ordered by the Court. The Association shall have the right to record a Notice of Violation against the Condominium of an Owner who is not in compliance with the provisions of the Project Documents if permitted by law. Failure by the Association or by any Owner to enforce any covenant or restriction herein contained shall in no event be deemed a waiver of the right to do so thereafter.

**9.2 Invalidity of Any Provision:** Should any provision or portion hereof be declared invalid or in conflict with any law of the jurisdiction where this Project is situated, the validity of all other provisions and portions hereof shall remain unaffected and in full force and effect.

**9.3 Term:** The covenants and restrictions of this Declaration shall run with and bind the Project, and shall inure to the benefit of and shall be enforceable by the Association or the Owner of any property subject to this Declaration, their respective legal representatives, heirs, successors and assigns, for a term of thirty (30) years from the date this Declaration is recorded, after which time they shall be automatically extended for successive periods of ten (10) years, unless an instrument in writing, signed by a majority of the then Owners of the Condominiums, has been recorded within the year preceding the beginning of each successive period of ten (10) years, agreeing to change said covenants and restrictions in whole or in part, or to terminate the same.

**9.4 Amendments:** This Declaration may be amended only by the affirmative vote (in person or by proxy) or written consent of Members representing a majority of the total voting power of the Association. However, the percentage of voting power necessary to amend a specific clause shall not be less than the prescribed percentage of affirmative votes required for action to be taken under that clause. Any amendment must be certified in a writing executed and acknowledged by the President or Vice President of the Association and recorded in the Recorder's Office of the County of San Mateo.

**9.5 Encroachment Rights:** If any portion of the Common Area encroaches on any Unit or any part thereof or any portion of a Unit encroaches on any Common Area due to engineering errors, errors or adjustments in original construction, reconstruction, repair, settlement, shifting, or movement of the building, or any other cause, the owner of the encroachment shall have the right to maintain, repair or replace the encroachment, as long as it exists, and the rights and obligations of Owners shall not be altered in any way by said encroachment, settlement or shifting; provided, however, that no right shall be created in favor of an Owner or Owners if said

encroachment occurred due to the intentional conduct of said Owner or Owners. In the event a structure is partially or totally destroyed, and then repaired or rebuilt, the Owners agree that minor encroachments over adjoining Condominiums or Common Area shall be permitted and that there shall be appropriate rights for the maintenance of said encroachments so long as they shall exist. In the event that an error in engineering, design or construction results in an encroachment of a building into the Common Area, or into or onto an adjoining lot, or into a required setback area, a correcting modification may be made in the subdivision map and/or Condominium Plan. Said modification may be in the form of a certificate of correction and shall be executed by the Association. The Board of Directors may, by vote or written approval of a majority of the directors, authorize the execution of the certificate of correction.

**9.6 Rights of First Lenders:** No breach of any of the covenants, conditions and restrictions herein contained, nor the enforcement of any lien provisions herein, shall render invalid the lien of any First Lender (meaning a Mortgage with first priority over any other Mortgage) on any Condominium made in good faith and for value, but all of said covenants, conditions and restrictions shall be binding upon and effective against any Owner whose title is derived through Foreclosure or trustee's sale, or otherwise. Notwithstanding any provision in the Condominium Documents to the contrary, First Lenders shall have the following rights:

**A. Copies of Project Documents:** The Association shall make available to Condominium Owners and First Lenders, and to holders, insurers or guarantors of any First Mortgage, current copies of the Declaration, Bylaws, Articles or other Rules concerning the Project and the books, records and financial statements of the Association. "Available" means available for inspection, upon request, during normal business hours or under other reasonable circumstances. The Board may impose a fee for providing the foregoing which may not exceed the reasonable cost to prepare and reproduce the requested documents.

**B. Audited Statement:** Any holder, insurer or guarantor of a First Mortgage shall be entitled, upon written request, to an audited financial statement for the immediately preceding fiscal year, free of charge to the party so requesting. Such statement shall be furnished within one hundred twenty (120) days of the Association's fiscal year-end.

**C. Notice of Action:** Upon written request to the Association, identifying the name and address of the Eligible Mortgage Holder or Eligible Insurer or Guarantor, and the Condominium number or address, such Eligible Mortgage Holder or Eligible Insurer or Guarantor will be entitled to timely written notice of:

(1) any condemnation loss or any casualty loss which affects a material portion of the Project or any Condominium on which there is a First Mortgage held, insured, or guaranteed by such Eligible Mortgage Holder or Eligible Insurer or Guarantor, as applicable;

(2) any default in performance of obligations under the Project Documents or delinquency in the payment of Assessments or charges owed by an Owner of a Condominium subject to a First Mortgage held, insured or guaranteed by such Eligible Mortgage Holder or Eligible Insurer or Guarantor, which remains uncured for a period of sixty (60) days;

(3) any lapse, cancellation or material modification of any insurance policy or fidelity bond maintained by the Association;

(4) any proposed action which would require the consent of a specified percentage of Eligible Mortgage Holders as specified in section 9.6D.

The Association shall discharge its obligation to notify Eligible Mortgage Holders or Eligible Insurers or Guarantors by sending written notices required herein to such parties, at the address given on the current request for notice, in the manner prescribed by section 9.9.

**D. Consent to Action:**



(1) Except as provided by statute or by other provision of the Project Documents in case of substantial destruction or condemnation of the Project, and further excepting any reallocation of interests in the Common Area(s) which might occur pursuant to any plan of expansion or phased development contained in the original Project Documents:

(a) the consent of Owners of Condominiums to which at least sixty-seven percent (67%) of the votes in the Association are allocated and the approval of Eligible Mortgage Holders holding Mortgages on Condominiums which have at least fifty-one percent (51%) of the votes of Condominiums subject to Eligible Mortgages, shall be required to terminate the legal status of the Project as a Condominium Project; provided, however, that if termination is for reasons other than substantial destruction or condemnation, the agreement of Eligible Mortgage Holders representing at least sixty-seven percent (67%) of the votes of the Mortgaged Units is required;

(b) the consent of Owners of Condominiums to which at least sixty-seven percent (67%) of the votes in the Association are allocated and the approval of Eligible Mortgage Holders holding Mortgages on Units which have at least fifty-one percent (51%) of the votes of the Condominiums subject to Eligible Mortgages, shall be required to add or amend any material provisions of the Project Documents which establish, provide for, govern or regulate any of the following: (i) voting rights; (ii) increases in Assessments that raise the previously assessed amount by more than twenty-five percent (25%), Assessment Liens, or the priority of Assessment Liens; (iii) reductions in reserves for maintenance, repair, and replacement of Common Areas; (iv) responsibility for maintenance and repairs; (v) reallocation of interests in the general or Restricted Common Areas, or rights to their use; (vi) convertibility of Units into Common Areas or vice versa; (vii) expansion or contraction of the Project, or the addition, annexation, or withdrawal of property to or from the Project; (viii) hazard or fidelity insurance requirements; (ix) imposition or any restrictions on the leasing of Units; (x) imposition of any restrictions on an Owner's right to sell or transfer his or her Unit; (xi) restoration or repair of the Project (after damage or partial condemnation) in a manner other than that specified in the Project Documents; or (xii) any provisions that expressly benefit Mortgage holders, insurers, or guarantors;

(c) an Eligible Mortgage Holder who receives a written request to approve additions or amendments who does not deliver or post to the requesting party a negative response within thirty (30) days after the notice of the proposed addition or amendment shall be deemed to have approved such request, provided the notice has been delivered to the Mortgage holder by certified or registered mail, return receipt requested.

(2) except as provided by statute in case of condemnation or substantial loss to the Condominiums and/or common elements of the Project, unless the holder(s) of at least two-thirds (2/3) of the First Mortgages (based upon one (1) vote for each First Mortgage owned), or Owners of the individual Condominiums have given their prior written approval, the Association and/or the Owners shall not be entitled to:

(a) by act or omission, seek to abandon or terminate the Condominium Project (except for abandonment or termination provided by law in the case of substantial destruction by fire or other casualty or in the case of a taking by condemnation or eminent domain);

(b) change the pro rata interest or obligations of any individual Condominium for the purpose of: (i) levying Assessments or charges or allocating distributions of hazard insurance proceeds or condemnation awards; or (ii) determining the pro rata share of ownership of each Condominium in the Common Area, provided that no Owner's undivided interest in the Common Area may be changed without the consent of that Owner;

(c) partition or subdivide any Condominium Unit;

(d) by act or omission, seek to abandon, partition, subdivide, encumber, sell or transfer the Common Area. (The granting of easements for public utilities or for other public purposes consistent with the intended use of the Common Area by the Condominium Project shall not be deemed a transfer within the meaning of this clause);

(e) use hazard insurance proceeds for losses to any of the Project (whether to Units or to Common Area) for other than the repair, replacement or reconstruction of such Project.

**E. Right of First Refusal:** The right of an Owner to sell, transfer, or otherwise convey his or her Condominium shall not be subject to any right of first refusal or similar restriction.

**F. Contracts:** Any agreement for professional management of the Project, or lease or any other contract providing for services of the developer, sponsor, or builder, may not exceed one (1) year. Any agreement, contract, or lease must provide for termination by either party for cause on thirty (30) days' written notice, or without cause and without payment of a termination fee or penalty on ninety (90) days' or less written notice.

**G. Reserves:** Condominium dues or charges shall include an adequate reserve fund for maintenance, repairs, and replacement of those improvements which the Association is obligated to maintain and that must be replaced on a periodic basis, and shall be payable in installments of Regular Assessments, rather than by Special Assessments.

**H. Priority of Liens:** Any Assessment Lien created under the provisions of this Declaration is expressly made subject and subordinate to the lien and encumbrance of any First Mortgage that encumbers all or any portion of the Project, or any Unit. Each First Lender who comes into possession of the Condominium by virtue of Foreclosure of the Mortgage, or any purchaser at a Foreclosure, will take the Condominium free of any claims for unpaid Assessments and fees, late charges, fines or interest levied in connection with such claims, against the Condominium which accrue prior to the time such First Lender or purchaser at a Foreclosure takes title to the Condominium, except for claims for a pro rata share of such Assessments or charges to all Condominiums including the mortgaged Condominium, and except for Assessment Liens as to which a Notice of Delinquent Assessment has been recorded prior to the Mortgage.

**I. Distribution of Insurance or Condemnation Proceeds:** No provision of the Condominium Documents gives an Owner, or any other party, priority over any rights of First Lenders in the case of a distribution to Owners of insurance proceeds or condemnation awards for losses to or taking of Condominiums and/or Common Area.

**J. Status of Loan to Facilitate Resale:** Any First Mortgage given to secure a loan to facilitate the resale of a Condominium after acquisition by foreclosure or by a deed in lieu of foreclosure or by an assignment in lieu of foreclosure, shall be deemed to be a loan made in good faith and for value and entitled to all of the rights and protections of Mortgages under this Declaration.

**K. Right to Appear at Meetings:** Any Eligible Mortgage Holder may appear (but cannot vote) at meetings of Owners and the Board to draw attention to violations of this Declaration that have not been corrected or that have been made the subject of remedial proceedings or Assessments.

**9.7 Owners' Compliance:** Each Owner, tenant or occupant of a Condominium shall comply with the provisions of this Declaration, and (to the extent they are not in conflict with the Declaration) the Articles and Bylaws, the decisions and resolutions of the Association or the Board, as lawfully amended from time to time. Failure to comply with any such decisions, or resolutions shall be grounds for an action (1) to recover sums due, (2) for damages, (3) for injunctive relief, (4) for costs and attorneys fees, or (5) any combination of the foregoing.

In the event of a violation of the Project Documents, the Association may record a Notice of Violation against the Condominium of the non-complying Owner. Upon recording a Notice of Violation, the Association shall have complete discretion in deciding whether, when and how to proceed with enforcement, and any delay after recording a Notice of Violation shall not give rise to a defense of waiver or estoppel in favor of a non-complying Owner. The Association may take action to enforce compliance against a subsequent Owner who acquires a Condominium with a recorded Notice of Violation. The right of the Association to record a Notice of Violation shall be in addition to all other rights and remedies the Association may have at law or under the Project Documents.

All agreements and determinations lawfully made by the Association in accordance with the voting percentages established in this Declaration or in the Articles or the Bylaws, shall be deemed to be binding on all Owners, their successors and assigns.

**9.8 Notice:** Any notice permitted or required by the Declaration, Articles or Bylaws may be delivered either personally or by mail. If delivery is by mail, it shall be deemed to have been delivered seventy-two (72) hours after a copy of the same has been deposited in the United States mail, first class or registered, postage prepaid, addressed to the person to be notified at the current address given by such person to the Secretary of the Board or addressed to the Unit of such person if no address has been given to the Secretary.

**9.9 Fair Housing:** No Owner shall, either directly or indirectly, forbid or restrict the conveyance, encumbrance, leasing, or mortgaging, or occupancy of his or her Unit to any person of a specified race, sex, sexual orientation, marital status, color, religion, ancestry, physical handicap, or national origin. The Project is age-restricted as senior citizen housing pursuant to Civil Code section 51.3, as provided in section 7.1.

**9.10. Dispute Resolution:** The Board is authorized to resolve any civil claim or action through alternative dispute resolution proceedings such as mediation, binding arbitration, or non-binding arbitration proceedings. Prior to the filing of an enforcement action for declaratory, injunctive, or writ relief in conjunction for monetary damages not in excess of Five Thousand Dollars (\$5,000), the Board, or any Owner who seeks such relief, shall first endeavor to submit the matter to alternative dispute resolution in compliance with the provisions of California Civil Code sections 1369.510-1369.580. The Board shall comply with the requirements of California Civil Code section 1369.590 by providing Members of the Association annually with a summary of the provisions of Article 2 (commencing with Civil Code section 1369.510) of Chapter 7 of Title 6 (Division 2, Part 4) of the California Civil Code, including the following language: "Failure of a Member of the Association to comply with the alternative dispute resolution requirements of Section 1369.520 of the Civil Code may result in the loss of your right to sue the Association or another Member of the Association regarding enforcement of the Governing Documents or the applicable law."

9.11 Number; Gender: The singular and plural number and masculine, feminine and neuter gender shall each include the other where the context requires.

IN WITNESS WHEREOF, the undersigned has executed this Amended and Restated Declaration this 11 day of October, 2005.

**MENLO COMMONS ASSOCIATION**

By: Helen Olson, Vice President *Helen Olson*  
Signature

**Certification**

I hereby certify and declare, under penalty of perjury, that the foregoing Amended and Restated Declaration has been approved by the written consent of not less than fifty-one percent (51%) of the Condominium Owners.

**MENLO COMMONS ASSOCIATION**

By: Kay Martin, Secretary *Kay Martin*  
Signature

STATE OF CALIFORNIA )

)

) ss.

COUNTY OF )

On this 11 day of October, 2005, before me, *Natasha V. Escareno*  
a notary public for the state, personally appeared *Helen Olson, Kay Martin* known to me or proved to me on the basis of satisfactory evidence to be the person(s) whose name(s) is/are subscribed to the within instrument, and acknowledged to me that he/she/they executed the same in his/her/their authorized capacity(ies), and that by his/her/their signature(s) on the instrument the person(s), or the entity upon behalf of which the person(s) acted, executed the instrument.

WITNESS my hand and official seal.

*Natasha V. Escareno*  
Notary Public, State of California

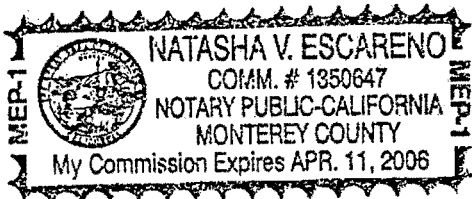

MENLO COMMONS  
EXHIBIT "A"

Assessment Schedule

<u>Building A</u> <u>Unit</u>	<u>Percentage of</u> <u>Assessment</u>	<u>Building B</u> <u>Unit</u>	<u>Percentage of</u> <u>Assessment</u>
A101	.80484	B101	.80484
A102	.87193	B102	.67077
A103	.87193	B103	.67077
A104	.80484	B104	.67077
A105	.67077	B105	.80484
A106	.80484	B106	.80484
		B107	.67077
		B108	.87193
		B109	.80484
A201	.80484	B201	.80484
A202	.67077	B202	.67077
A203	.67077	B203	.67077
A204	.67077	B204	.67077
A205	.80484	B205	.80484
A206	.80484	B206	.80484
A207	.67077	B207	.67077
A208	.67077	B208	.67077
A209	.67077	B209	.67077
A210	.80484	B210	.80484
A301	.87193	B301	.87193
A302	.87193	B302	.87193
A303	.72610	B303	.72610
A304	.87193	B304	.87193
A305	.87193	B305	.87193
A306	.72610	B306	.72610

<u>Building C</u> <u>Unit</u>	<u>Percentage of</u> <u>Assessment</u>	<u>BuildingD</u> <u>Unit</u>	<u>Percentage of</u> <u>Assessment</u>
C101	.80484	D101	.80484
C102	.82720	D102	.87193
C103	.87193	D103	.87193
C104	.87193	D104	.80484
C105	.80484	D105	.82720
C106	.80484	D106	.87193
C107	.87193	D107	.87193
C108	.87193	D108	.80484
C109	.87193		
C110	.80484		
C201	.80484	D201	.80484
C202	.84962	D202	.87193
C203	.87193	D203	.87193
C204	.87193	D204	.80484
C205	.80484	D205	.84962
C206	.80484	D206	.87193
C207	.87193	D207	.87193
C208	.87193	D208	.80484
C209	.87193		
C210	.80484		
C301	.93893	D301	.93893
C302	.93893	D302	.93893
C303	.93893	D303	.93893
C304	.72610	D304	.93893
C305	.67077	D305	.93893
C306	.93893		
C307	.93893		

<u>Building E Unit</u>	<u>Percentage of Assessment</u>
----------------------------	-------------------------------------

E101	.80484
E102	.87193
E103	.87193
E104	.87193
E105	.80484
E106	.80484
E107	.82720
E108	.87193
E109	.87193
E110	.80484

E201	.80484
E202	.87193
E203	.87193
E204	.87193
E205	.80484
E206	.80484
E207	.84962
E208	.87193
E209	.87193
E210	.80484

E301	.72610
E302	.67077
C303	.93893
E304	.93893
E305	.93893
E306	.93893
E307	.93893





**MENLO COMMONS  
EXHIBIT "B"**

**Items Covered by Maintenance Provisions**

	Responsibility	
	<u>Association</u>	<u>Owner</u>
Air conditioning equipment		X
Awnings		X
Balcony drains, cleaning		X
Caulking – bath tub or Shower		X
Doors – 3rdfloor deck storage area	X	
Drawer guides		X
Drains	X	
Faucets		X
Filters – Kitchen faucet, range exhaust		X
Fireplaces		X
Garage Gate remote control		X
Garage parking space – drip pans		X
Garage cleaning	X	
Kitchen cabinet repairs/replacement		X
Kitchen appliances, all		X
Knobs –Doors- Cabinets		X
Lights –Bulbs – fluorescent tubes, diffusers		X
Lockers (in the garage)		X
Pest control – rats, mice, ants, silverfish	X	
Phone jacks (original)	X	
Plumbing (inside walls)	X	
Rollers – Closet doors		X
Radiant heat ceiling panels	X	
Screens		X
Showers		X
Smoke detectors		X
Switches		X
TV outlets (original)	X	
Toilets – seats, seals, tank, lid, bowl		X
Towel bars – new, replacement, repair		X
Vacuum system-central	X	
Water pipes	X	
Windows-glass, rollers		X

The Board may provide repair and installation services for those items or portions of items that are the responsibility of Owners, provided that the Owner requesting such service shall be specially assessed for the labor and materials used.



MENLO COMMONS

EXHIBIT "C"

CIVIL CODE SECTION 51.3

51.3. (a) The Legislature finds and declares that this section is essential to establish and preserve specially designed accessible housing for senior citizens. There are senior citizens who need special living environments and services, and find that there is an inadequate supply of this type of housing in the state.

(b) For the purposes of this section, the following definitions apply:

(1) "Qualifying resident" or "senior citizen" means a person 62 years of age or older, or 55 years of age or older in a senior citizen housing development.

(2) "Qualified permanent resident" means a person who meets both of the following requirements:

(A) Was residing with the qualifying resident or senior citizen prior to the death, hospitalization, or other prolonged absence of, or the dissolution of marriage with, the qualifying resident or senior citizen.

(B) Was 45 years of age or older, or was a spouse, cohabitant, or person providing primary physical or economic support to the qualifying resident or senior citizen.

(3) "Qualified permanent resident" also means a disabled person or person with a disabling illness or injury who is a child or grandchild of the senior citizen or a qualified permanent resident as defined in paragraph (2) who needs to live with the senior citizen or qualified permanent resident because of the disabling condition, illness, or injury. For purposes of this section, "disabled" means a person who has a disability defined in subdivision (b) of Section 54.A "disabling injury or illness" means an illness or injury which results in a condition meeting the definition of disability set forth in subdivision (b) of Section 54.

(A) For any person who is a qualified permanent resident under this paragraph whose disabling condition ends, the owner, board of directors, or other governing body may require the formerly disabled resident to cease residing in the development upon receipt of six months' written notice; provided, however, that the owner, board of directors, or other governing body may allow the person to remain a resident for up to one year after the disabling condition ends.

(B) The owner, board of directors, or other governing body of the senior citizen housing development may take action to prohibit or terminate occupancy by a person who is a qualified permanent resident under this paragraph if the owner, board of directors, or other governing body finds, based on credible and objective evidence, that the person is likely to pose a significant threat to the health or safety of others that cannot be ameliorated by means of a reasonable accommodation; provided, however, that the action to prohibit or terminate the occupancy may be taken only after doing both of the following:

(i) Providing reasonable notice to and an opportunity to be heard for the disabled person whose occupancy is being challenged, and reasonable notice to the coresident parent or grandparent of that person.

(ii) Giving due consideration to the relevant, credible, and objective information provided in the hearing. The evidence shall be taken and held in a confidential manner, pursuant to a closed session, by the owner, board of directors, or other governing body in order to preserve the privacy of the affected persons.

The affected persons shall be entitled to have present at the hearing an attorney or any other person authorized by them to speak on their behalf or to assist them in the matter.

(4) "Senior citizen housing development" means a residential development developed, substantially rehabilitated, or substantially renovated for, senior citizens that has at least 35 dwelling units.

Any senior citizen housing development which is required to obtain a public report under Section 11010 of the Business and Professions Code and which submits its application for a public report after July 1, 2001, shall be required to have been issued a public report as a senior citizen housing development under Section 11010.05 of the Business and Professions Code. No housing development constructed prior to January 1, 1985, shall fail to qualify as a senior citizen housing development because it was not originally developed or put to use for occupancy by senior citizens.

(5) "Dwelling unit" or "housing" means any residential accommodation other than a mobilehome.

(6) "Cohabitant" refers to persons who live together as husband and wife, or persons who are domestic partners within the meaning of Section 297 of the Family Code.

(7) "Permitted health care resident" means a person hired to provide live-in, long-term, or terminal health

care to a qualifying resident, or a family member of the qualifying resident providing that care. For the purposes of this section, the care provided by a permitted health care resident must be substantial in nature and must provide either assistance with necessary daily activities or medical treatment, or both. A permitted health care resident shall be entitled to continue his or her occupancy, residency, or use of the dwelling unit as a permitted resident in the absence of the senior citizen from the dwelling unit only if both of the following are applicable:

(A) The senior citizen became absent from the dwelling due to hospitalization or other necessary medical treatment and expects to return to his or her residence within 90 days from the date the absence began.

(B) The absent senior citizen or an authorized person acting for the senior citizen submits a written request to the owner, board of directors, or governing board stating that the senior citizen desires that the permitted health care resident be allowed to remain in order to be present when the senior citizen returns to reside in the development.

Upon written request by the senior citizen or an authorized person acting for the senior citizen, the owner, board of directors, or governing board shall have the discretion to allow a permitted health care resident to remain for a time period longer than 90 days from the date that the senior citizen's absence began, if it appears that the senior citizen will return within a period of time not to exceed an additional 90 days.

(c) The covenants, conditions, and restrictions and other documents or written policy shall set forth the limitations on occupancy, residency, or use on the basis of age. Any such limitation shall not be more exclusive than to require that one person in residence in each dwelling unit may be required to be a senior citizen and that each other resident in the same dwelling unit may be required to be a qualified permanent resident, a permitted health care resident, or a person under 55 years of age whose occupancy is permitted under subdivision (h) of this section or under subdivision (b) of Section 51.4. That limitation may be less exclusive, but shall at least require that the persons commencing any occupancy of a dwelling unit include a senior citizen who intends to reside in the unit as his or her primary residence on a permanent basis. The application of the rules set forth in this subdivision regarding limitations on occupancy may result in less than all of the dwellings being actually occupied by a senior citizen.

(d) The covenants, conditions, and restrictions or other documents or written policy shall permit temporary residency, as a guest of a senior citizen or qualified permanent resident, by a person of less than 55 years of age for periods of time, not less than 60 days in any year, that are specified in the covenants, conditions, and restrictions or other documents or written policy.

(e) Upon the death or dissolution of marriage, or upon hospitalization, or other prolonged absence of the qualifying resident, any qualified permanent resident shall be entitled to continue his or her occupancy, residency, or use of the dwelling unit as a permitted resident. This subdivision shall not apply to a permitted health care resident.

(f) The condominium, stock cooperative, limited-equity housing cooperative, planned development, or multiple-family residential rental property shall have been developed for, and initially been put to use as, housing for senior citizens, or shall have been substantially rehabilitated or renovated for, and immediately afterward put to use as, housing for senior citizens, as provided in this section; provided, however, that no housing development constructed prior to January 1, 1985, shall fail to qualify as a senior citizen housing development because it was not originally developed for or originally put to use for occupancy by senior citizens.

(g) The covenants, conditions, and restrictions or other documents or written policies applicable to any condominium, stock cooperative, limited-equity housing cooperative, planned development, or multiple-family residential property that contained age restrictions on January 1, 1984, shall be enforceable only to the extent permitted by this section, notwithstanding lower age restrictions contained in those documents or policies.

(h) Any person who has the right to reside in, occupy, or use the housing or an unimproved lot subject to this section on January 1, 1985, shall not be deprived of the right to continue that residency, occupancy, or use as the result of the enactment of this section.

(i) The covenants, conditions, and restrictions or other documents or written policy of the senior citizen housing development shall permit the occupancy of a dwelling unit by a permitted health care resident during any period that the person is actually providing live-in, long-term, or hospice health care to a qualifying resident for compensation. For purposes of this subdivision, the term "for compensation" shall include provisions of lodging and food in exchange for care.

(j) Notwithstanding any other provision of this section, this section shall not apply to the County of Riverside.

**MENLO COMMONS  
EXHIBIT "D"**

**The Plan**

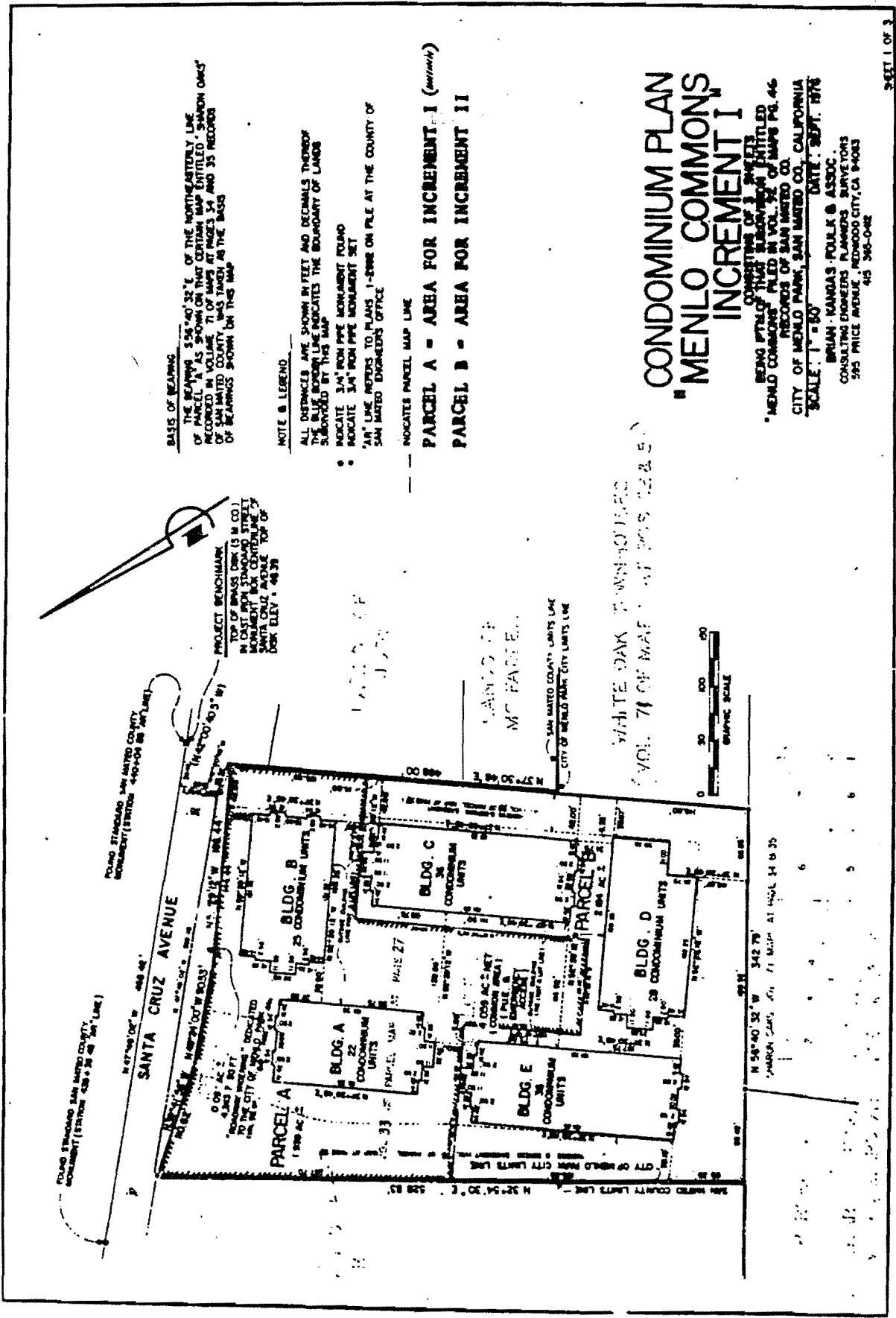

**BASES OF BEARINGS**  
 THE BEARINGS S56°40'32"E OF THE NORTHEASTLY LINE OF PARCEL "A" AS SHOWN ON THAT CERTAIN MAP ENTITLED "SHAWON OAKS" RECORDED IN VOLUME 71 OF MAPS AT PAGES 34 AND 35 RECORDS OF SAN MATEO COUNTY, WAS TAKEN AS THE BASIS OF BEARINGS SHOWN ON THIS MAP

**NOTE & LEGEND**

- ALL DISTANCES ARE SHOWN IN FEET AND DECIMALS THEREOF
- THE BLUE BOUNDARY LINE INDICATES THE BOUNDARY OF LANDS SUBDIVIDED BY THIS MAP
- INDICATE 3/4" NON PIPE MONUMENT FOUND
- INDICATE 3/4" NON PIPE MONUMENT SET
- "AR" LINE REFERS TO PLANS 1-5888 ON FILE AT THE COUNTY OF SAN MATEO ENGINEER'S OFFICE

--- INDICATES PARCEL MAP LINE

**PARCEL A - AREA FOR INCREMENT I (partially)**

**PARCEL B - AREA FOR INCREMENT II**

**CONDOMINIUM PLAN  
 - MENLO COMMONS  
 INCREMENT I**

CONSISTING OF 1 SHEETS  
 BEING PFD NO. 71 MAPS ENTITLED  
 "MENLO COMMONS" FILED IN VOL. 71 OF MAPS PG. 46  
 CITY OF MENLO PARK, SAN MATEO CO., CALIFORNIA  
 SCALE: 1" = 80' DATE: SEPT. 1978

BRIAN VANDAS - P.O.L.K. & ASSOC.  
 CONSULTING ENGINEERS PLANNERS SURVEYORS  
 595 PRICE AVENUE, REDWOOD CITY, CA 94063  
 415 386-0486

ROAD STATIONING SAN MATEO COUNTY DOCUMENT (STRONG 460-04 88 30' LINE)  
 ROAD STATIONING SAN MATEO COUNTY DOCUMENT (STRONG 460-04 88 30' LINE)  
 SANTA CRUZ AVENUE  
 PROJECT BENCHMARK  
 TOP OF BRASS DISK (3 M CO.)  
 IN EAST SIDE STIMMOND STREET  
 SUBMITTAL FOR CENTERLINE OF  
 ROAD ELEV. 483.29

WHITE OAK TOWNHOUSES  
 (VOL. 71 OF MAPS AT PAGES 22 & 5)

GRAPHIC SCALE  
 0 20 40 60 80

N 56°40'32" W 342.79'  
 "MARKS CORNER" 71 MAP AT PAGE 34 & 35

1 2 3 4 5 6





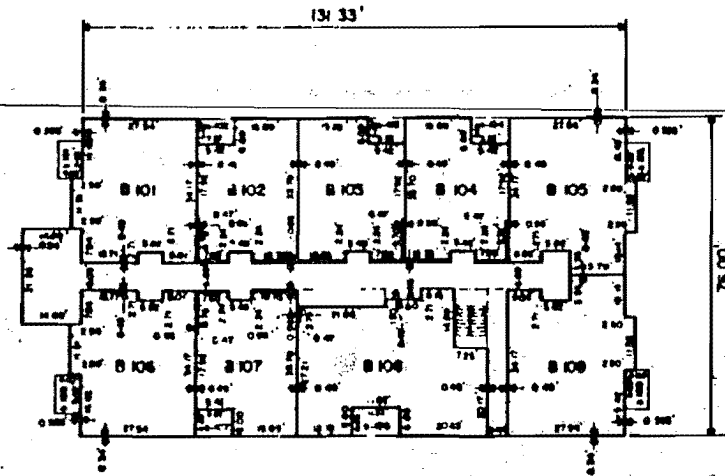

**1<sup>st</sup> FLOOR - FLOOR PLAN  
BUILDING "B"**  
1<sup>st</sup> FLOOR ELEV. = 61.08'  
1<sup>st</sup> FLOOR CEILING ELEV. = 69.08'

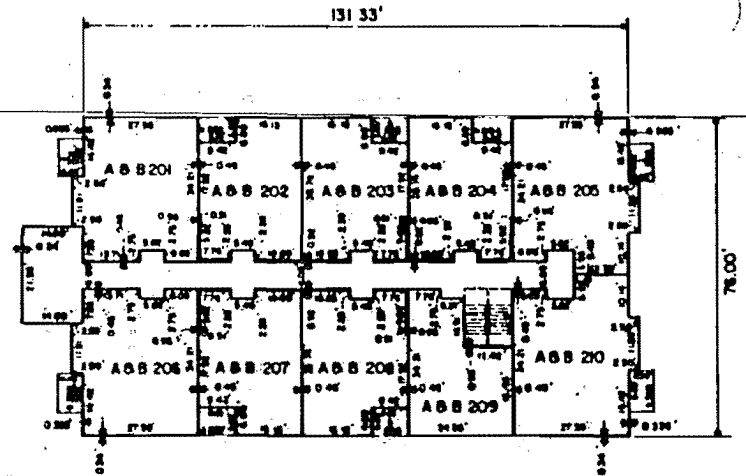

**2<sup>nd</sup> FLOOR - FLOOR PLAN  
BUILDING "A" & "B"**  
BLDG A 2<sup>nd</sup> FLOOR ELEV. = 76.42'    BLDG B 2<sup>nd</sup> FLOOR ELEV. = 70.17'  
2<sup>nd</sup> FLOOR CEILING ELEV. = 84.42'    2<sup>nd</sup> FLOOR CEILING ELEV. = 78.17'

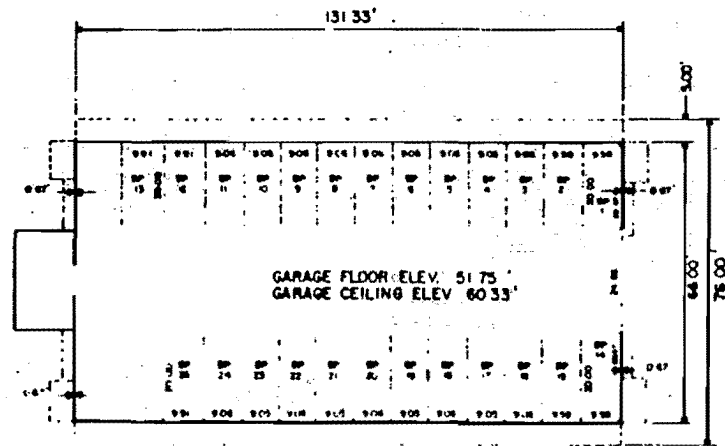

**BASEMENT - FLOOR PLAN  
BUILDING "B"**

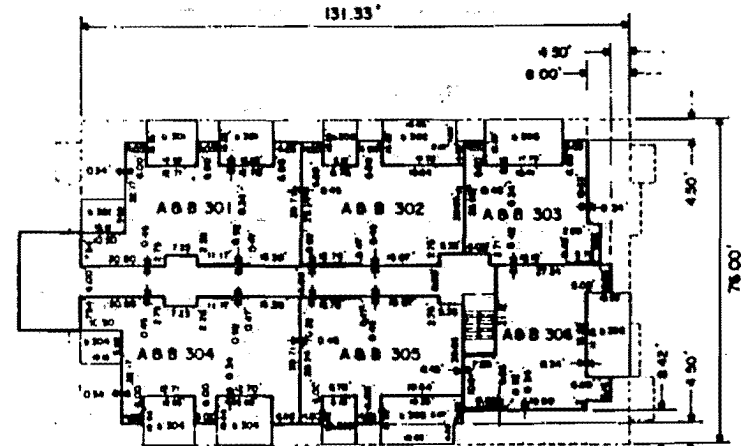

**3<sup>rd</sup> FLOOR - FLOOR PLAN  
BUILDING "A" & "B"**  
BLDG A 3<sup>rd</sup> FLOOR ELEV. = 85.67'  
3<sup>rd</sup> FLOOR CEILING ELEV. = 93.67'  
BLDG B 3<sup>rd</sup> FLOOR ELEV. = 79.42'  
3<sup>rd</sup> FLOOR CEILING ELEV. = 87.42'

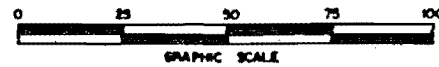

**CONDOMINIUM PLAN  
"MENLO COMMONS"**  
FLOOR PLANS  
CITY OF MENLO PARK, SAN MATEO CO. CALIF.  
SCALE 1/8" = 1'-0"    DATE SEPT 1976

CITY OF MENLO PARK, SAN MATEO COUNTY, CALIFORNIA

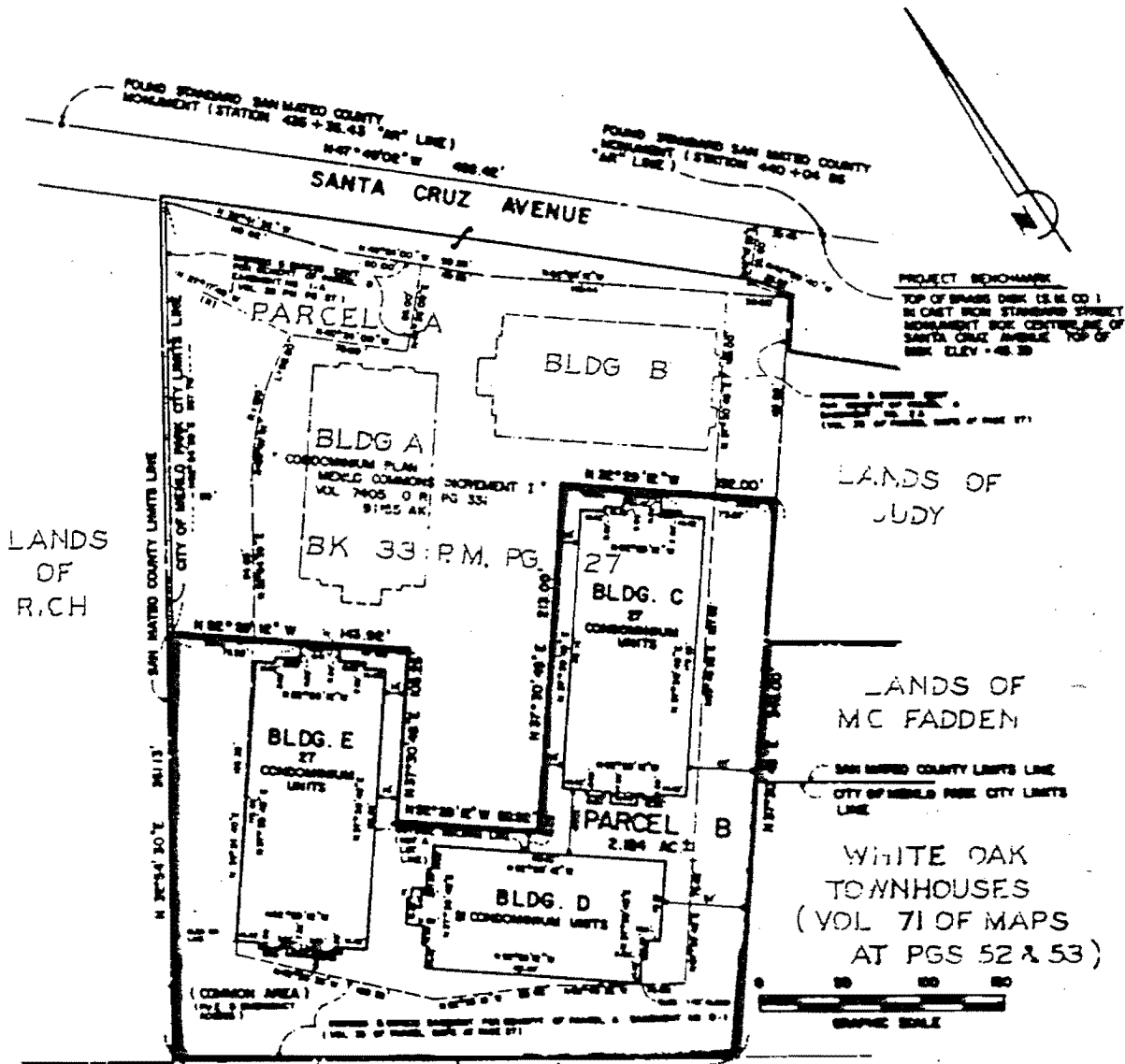

N 89°40'30" W 346.70'  
SHARON OAKS VOL. 71 MAPS AT PAGE 34 & 35

PARCEL A	1	2	3	4	5	6	7
SHARON HEIGHTS UNIT NO. 14							
VOL. 65 MAPS AT PAGE 38 & 39							

# BUILDING "C"

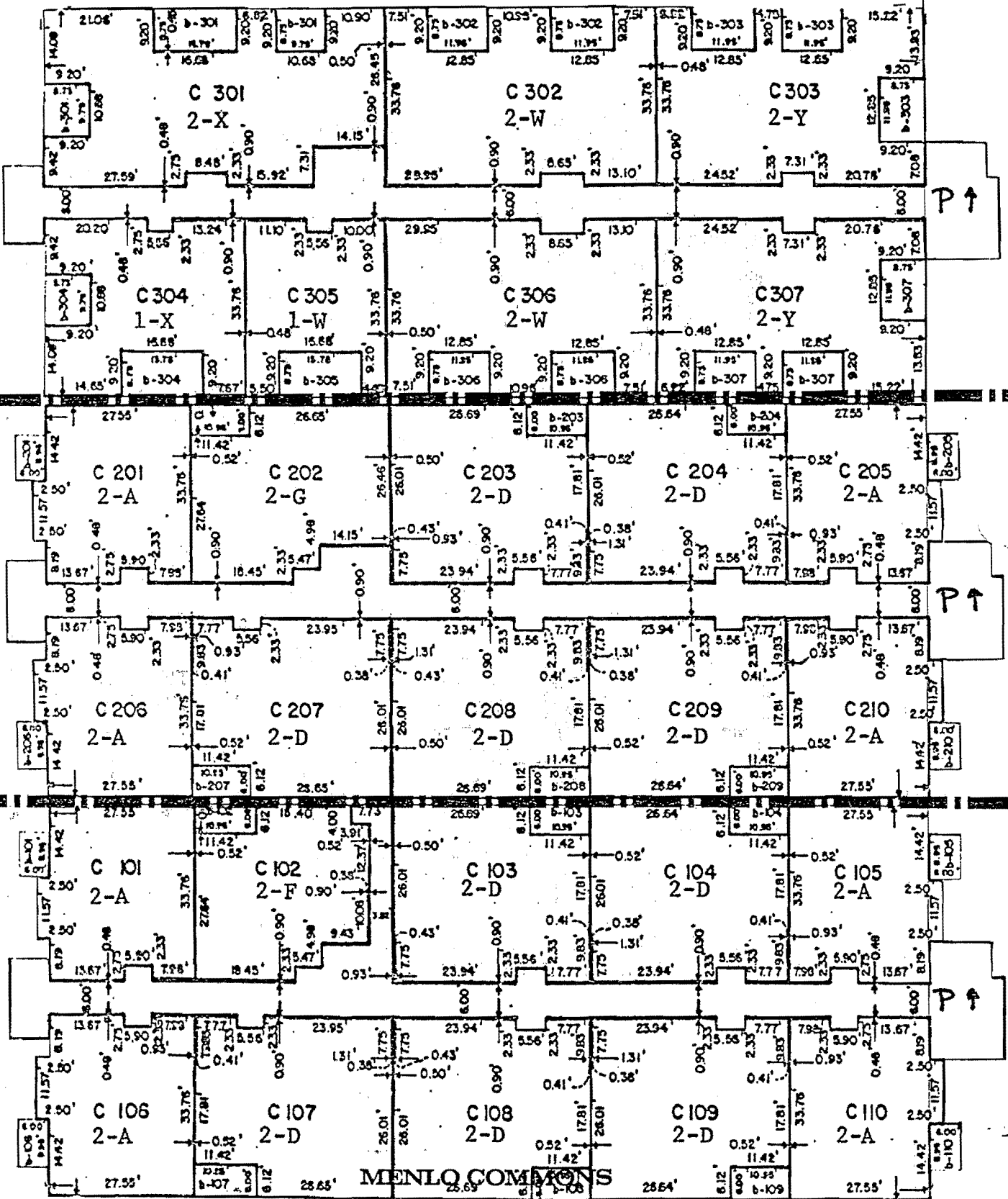

BUILDING 'D'

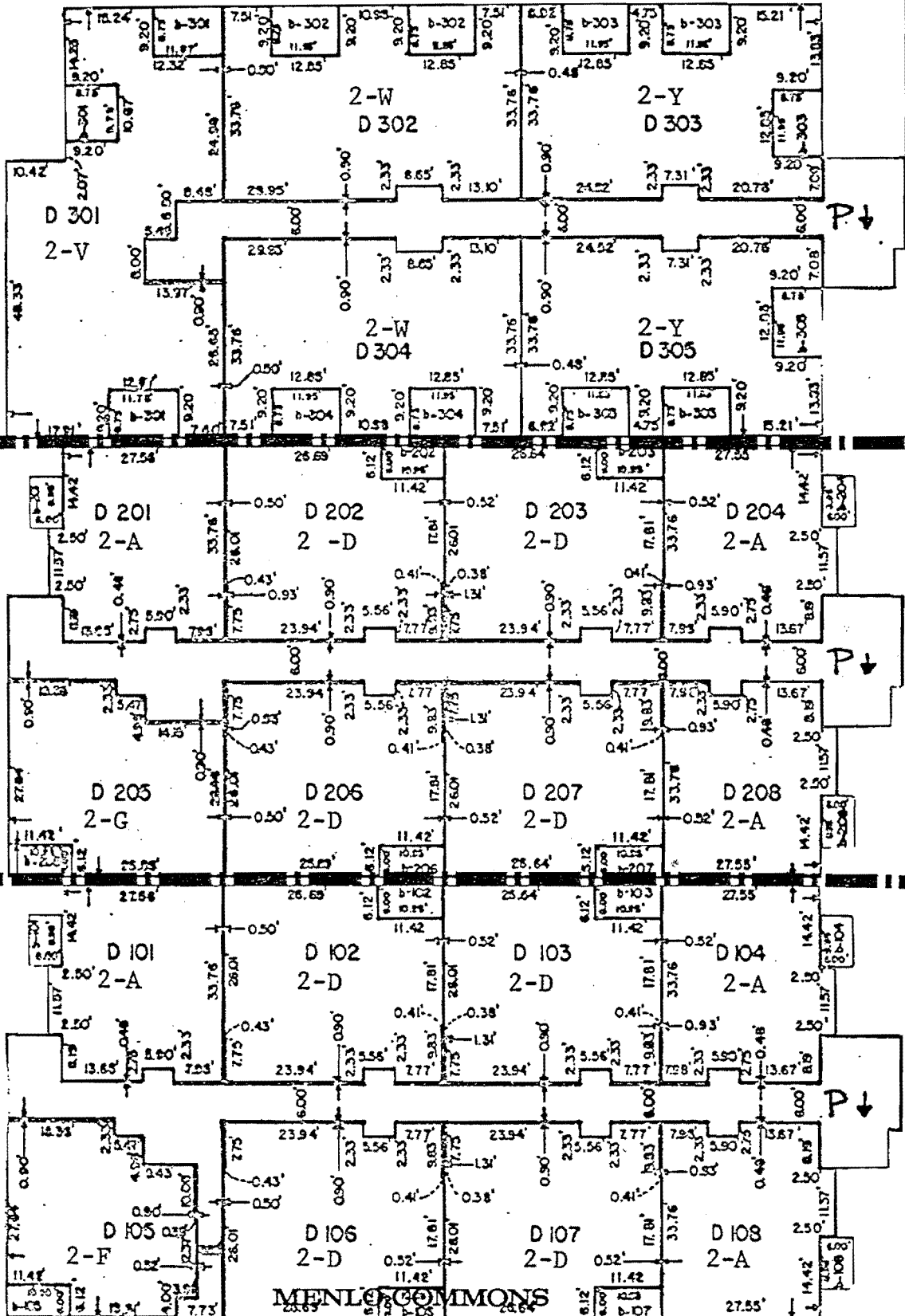



MENLO COMMONS HOMEOWNERS ASSOCIATION

AMENDED BYLAWS

TABLE OF CONTENTS

	<u>Page #</u>
<b>ARTICLE I</b>	
NAME AND LOCATION .....	1
1.1 Name and Location .....	1
<b>ARTICLE II</b>	
DEFINITIONS .....	1
2.1 Incorporation .....	1
2.2 Declaration .....	1
<b>ARTICLE III</b>	
MEETING OF MEMBERS AND VOTING .....	1
3.1 Annual Meeting .....	1
3.2 Special Meetings .....	1
3.3 Notice and Place of Meetings .....	1
3.4 Quorum .....	2
3.5 Proxies .....	2
3.6 Membership and Voting Rights .....	2
3.7 Eligibility to Vote .....	2
3.8 Record Dates .....	3
A. Record Dates Established by the Board .....	3
1. Record Date for Notice of Meetings .....	3
2. Record Date for Voting .....	3
3. Record Date for Action by Written Ballot Without Meeting .....	3
4. Record Date for Other Lawful Action .....	4
5. Record Date Means as of Close of Business .....	4
3.9 Action without Meeting .....	4
3.10 Conduct of Meetings .....	4
<b>ARTICLE IV</b>	
<b>BOARD OF DIRECTORS; SELECTION; TERM OF OFFICE</b>	
4.1 General	
4.2 Number	
4.3 Term of Office	

*Law Offices of*  
Hanna & Van Atta  
525 UNIVERSITY AVENUE, SUITE 705  
PALO ALTO, CA 94301  
TELEPHONE (650) 321-5700

4.4	Compensation .....	4
4.5	Indemnification of Corporate Agents .....	4

**ARTICLE V**

NOMINATION AND ELECTION OF DIRECTORS .....	5
--	---

5.1	Nomination .....	5
5.2	Election .....	5

**ARTICLE VI  
MEETINGS OF DIRECTORS**

6.1	Regular Meetings .....	5
6.2	Special Meetings .....	5
6.3	Emergency Meetings .....	6
6.4	Quorum .....	6
6.5	Open Meetings .....	6
6.6	Executive Session .....	6
6.7	Telephone/Electronic Meetings .....	6
6.8	Waiver of Notice .....	7
6.9	Notice of Adjourned Meeting .....	7
6.10	Action Without Meeting .....	7
6.11	Definition of Meeting .....	7
6.12	Availability of Minutes .....	7

**ARTICLE VII  
POWERS AND DUTIES OF THE BOARD OF DIRECTORS**

7.1	Duties .....	7
	A. Adopt Policies .....	7
	B. Oversight and Review of Administration of Association Affairs .....	7
	C. Supervision .....	8
7.2	Powers .....	8
	A. Manager .....	8
	B. Adoption of Rules .....	8
	C. Assessments, Liens and Fines .....	8
	D. Enforcement (Notice and Hearing) .....	8
	E. Contracts.....	8
	F. Delegation .....	9
	G. Appointment of Trustee .....	9
	H. Other Powers .....	9

**ARTICLE VIII  
ASSOCIATION DUTIES AND RESPONSIBILITIES**

8.1	Association Duties .....	9
	A. Maintenance .....	9
	B. Insurance .....	9
	C. Discharge of Liens .....	9
	D. Assessments .....	9
	E. Expenses and Obligations .....	9
	F. Enforcement .....	9



G.	Records .....	9
H.	Contracts .....	10
I.	Financial Requirements .....	10

**ARTICLE IX  
OFFICERS AND THEIR DUTIES**

9.1	Enumeration of Officers .....	10
9.2	Election of Officers .....	10
9.3	Term .....	10
9.4	Special Appointments .....	10
9.5	Resignation and Removal .....	10
9.6	Vacancies .....	10
9.7	Duties .....	10
A.	President .....	10
B.	Vice President .....	10
C.	Secretary .....	10
D.	Chief Financial Officer (Treasurer).....	10

**ARTICLE X  
COMMITTEES**

10.1	Nominating Committees .....	11
10.2	Other Committees .....	11
10.3	Limitations on Committees .....	11
10.4	Purpose of Committees .....	11

**ARTICLE XI  
BOOKS AND RECORDS**

11.1	Inspection by Members .....	11
11.2	Rules for Inspection .....	11
11.3	Inspection by Directors .....	11
11.4	Documents Provided by Association .....	12

**ARTICLE XII  
FINANCIAL AND REPORTING REQUIREMENTS**

12.1	Budgets, Financial Statements and Reports .....	12
12.2	Reserve Studies .....	14
12.3	Reserve Account Fund Management.....	15
12.4	Reserve Account Withdrawal Restrictions .....	15
12.5	Review of Financial Records .....	15
12.6	Future Changes in Financial Records and Reserve Account Requirements .....	15

**ARTICLE XIII  
MISCELLANEOUS**

13.1	Amendments .....	16
13.2	Conflicts .....	16
13.3	Fiscal Year .....	16

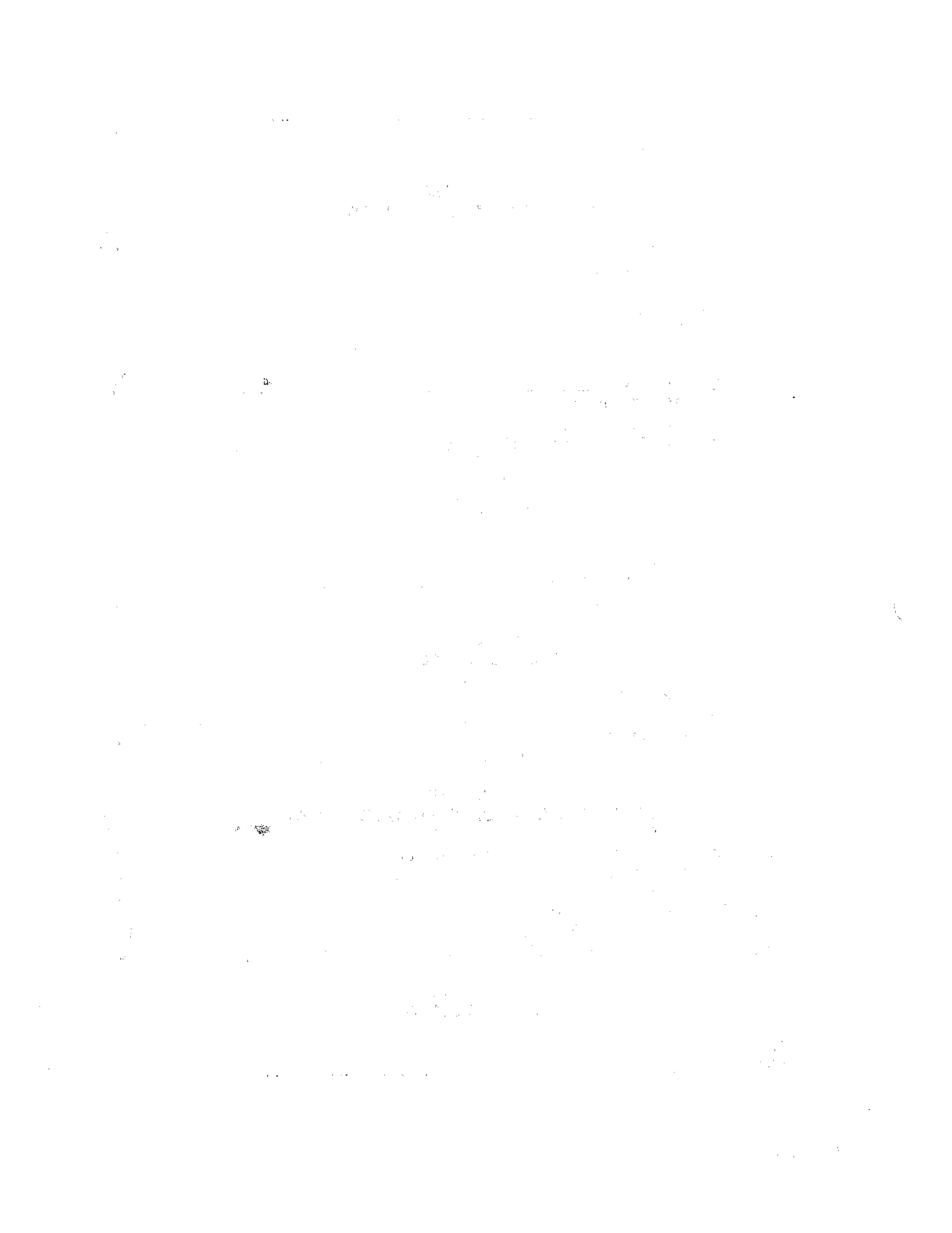

**AMENDED BYLAWS OF  
MENLO COMMONS HOMEOWNERS ASSOCIATION**

This Amendment to the Bylaws of MENLO COMMONS HOMEOWNERS ASSOCIATION is made on the date hereinafter set forth pursuant to the written consent of Members constituting a majority of the total voting power of the Association. By this Amendment, the Members intend to, and do supersede the original Bylaws (as previously amended) in their entirety. Upon execution of these Bylaws, this Amendment to the Bylaws shall be in full force and effect and the original Bylaws shall cease to be of any force or effect.

**ARTICLE I  
NAME AND LOCATION**

**1.1 Name and Location.** The name of the corporation is MENLO COMMONS HOMEOWNERS ASSOCIATION, hereinafter referred to as the "Association." The principal office of the Association shall be located at the Project or at such other place as may be designated by the Board.

**ARTICLE II  
DEFINITIONS**

**2.1 Incorporation.** The definitions contained in the Declaration are incorporated by reference herein.

**2.2 Declaration.** "Declaration" shall mean and refer to the Menlo Commons Homeowners Association Amended and Restated Declaration of Covenants, Conditions and Restrictions (CC&R) applicable to the Property recorded in San Mateo County, and subsequent amendments thereto.

**ARTICLE III  
MEETING OF MEMBERS AND VOTING**

**3.1 Annual Meeting.** The annual meetings shall be held on the last Monday of October each year at 7:30 P.M. If the day for the annual meeting of the Members is a legal holiday, the meeting will be held at the same hour on the first day following, which is not a legal holiday (excluding Saturday and Sunday).

**3.2 Special Meetings.** Special meetings of the Members shall be promptly scheduled at any time by the Board in response to the vote of a majority of the Board of Directors, or in response to a request by the Chairman of the Board, the President, or upon written request of the Members

**3.3 Notice and Place of Meetings.** Written notice of each meeting of the Members, annual or special, shall be given by, or at the direction of, the Secretary, by personal delivery or by mailing a copy of such notice, first-class mail, postage prepaid, or e-mail, at least ten (10) but not more than ninety (90) days before such meeting to each First Lender requesting notice and to all Members, addressed to the Member's address last appearing on the books of the Association, or supplied by such Member to the Association for the purpose of notice. [2792.17(d); Corp Code §7511] Such notice shall specify the place, day and hour of the meeting, and, in the case of a special meeting, the purpose of the meeting. If action is proposed to be taken at any meeting for approval for any of the following proposals, the notice shall also state the general nature of the proposal. : (a) removing a director without cause; (b) filling vacancies in the Board of Directors by the Members; (c) amending the Articles of Incorporation; (d) approving a contract or transaction in which a director has a material financial interest; or (e)

dissolving the Association. Member action on such items is invalid unless the notice of meeting or written waiver of notice states the general nature of the proposal(s). Meetings shall be held within the Project or at a meeting place within the same county, as close to the Project as possible.

**3.4 Quorum.** The presence either in person or by proxy, at any meeting, of Members entitled to cast fifty-one percent (51%) of the total voting power of the Association (excluding the number of votes as to which voting rights are suspended at the time of the subject meeting), shall constitute a quorum for any action except as otherwise provided in the Declaration, or these Bylaws. If, however, such quorum shall not be present or represented at any meeting, a majority of the Members entitled to vote thereat shall have power to adjourn the meeting to a date not less than five (5) days and not more than thirty (30) days later, without notice other than announcement at the meeting, until a quorum as aforesaid shall be present or be represented.

The Members present at a duly called or held meeting at which a quorum is present may continue to do business until adjournment, notwithstanding the withdrawal of enough Members to leave less than a quorum, provided that twenty-five percent (25%) of the total voting power of the Association remains present in person and/or by proxy, and provided further that any action taken shall be approved by a majority of the Members required to constitute a quorum, and that the only matters that may be voted upon at said adjourned meeting are matters the general nature of which was noticed not less than ten (10) nor more than ninety (90) days before the date of the meeting to each Member entitled to vote at the meeting. If a time and place for the adjourned meeting is not fixed by those in attendance at the original meeting or if for any reason a new date is fixed for the adjourned meeting after adjournment, notice of the time and place of the adjourned meeting shall be given to Members in the manner prescribed for annual meetings.

Notwithstanding anything herein to the contrary, for purposes of obtaining membership approval of special Assessments or increases in annual Assessments as may be required by section 4.4 of the Declaration, a "quorum" means Members constituting more than fifty percent (50%) of the Members of the Association.

**3.5 Proxies.** At all meetings of Members, each Member may vote in person or by proxy. All proxies shall be in writing and filed with the Secretary before the appointed time of each meeting. Every proxy shall be revocable and shall automatically cease upon conveyance by the Member of his Unit, or upon receipt of written notice by the Secretary of the Board of the death or judicially declared incompetence of a Member prior to the counting of the vote, or upon the expiration of eleven (11) months from the date of the proxy. Any form of proxy distributed by any person to the membership of the Association shall afford the opportunity to specify a choice between approval and disapproval of each matter or group of matters to be acted upon. The proxy shall provide that, where the Member specifies a choice, the vote shall be cast in accordance with that choice. The proxy also shall identify the person or persons authorized to exercise the proxy and the length of time it will be valid. In addition, voting by proxy shall comply with any other applicable requirements of California Corporation Code §§ 7514 and 7613.

**3.6 Membership and Voting Rights.** All Owners shall be Members and shall be entitled to one (1) vote for each Condominium owned. When more than one (1) person holds an interest in any Condominium, all such persons shall be Members. The vote for such Condominium shall be exercised as they among themselves determine, but in no event shall more than one (1) vote be cast with respect to any Condominium.

Any action by the Association which must have the approval of the Members before being undertaken shall require the vote or written assent of Members constituting a majority of the total voting power of the Association.

**3.7 Eligibility to Vote:** Only Members in good standing shall be entitled to vote on any issue or matter presented to the Members for approval. In order to be in good standing, a Member must be current in the payment of all Assessments levied against the Member's Unit and not subject to any

suspension of voting privileges as a result of any disciplinary proceeding conducted in accordance with the Declaration. A Member's good standing shall be determined as of the record date established in accordance with section 3.8. The Association shall not be obligated to conduct a hearing in order to suspend a Member's voting privileges on the basis of the nonpayment of Assessments, although a delinquent Member shall be entitled to request such a hearing. A Member shall maintain good standing if said standing has not been suspended by the provisions of these Bylaws and the Member has maintained a current filing with the Association of the following: (i) the signature or signatures of the Owner(s) authorized to vote on behalf of the Member's Unit; and (ii) address where all notices shall be sent; or, alternatively, (iii) a proxy that names the Owner's representative and lists said representative's address.

### **3.8 Record Dates:**

**A. Record Dates Established by the Board:** For the purpose of determining which Members are entitled to receive notice of any meeting, vote, act by written ballot without a meeting, or exercise any rights in respect to any other lawful action, the Board may fix, in advance, a "record date" and only Members of record on the date so fixed are entitled to receive notice, to vote, or to take action by written ballot or otherwise, as the case may be, notwithstanding any transfer of any membership on the books of the Association after the record date, except as otherwise provided in the Articles, by agreement, or in the California Nonprofit Mutual Benefit Corporation Law. The record dates established by the Board pursuant to this section shall be as follows:

(1) **Record Date for Notice of Meetings:** In the case of determining those Members entitled to notice of a meeting, the record date shall be no more than ninety (90) nor less than ten (10) days before the date of the meeting;

(2) **Record Date for Voting:** In the case of determining those Members entitled to vote at a meeting, the record date shall be no more than sixty (60) days before the date of the meeting;

(3) **Record Date for Action by Written Ballot Without Meeting:** In the case of determining Members entitled to cast written ballots, the record date shall be no more than sixty (60) days before the day on which the first written ballot is mailed or solicited; and

(4) **Record Date for Other Lawful Action:** In the case of determining Members entitled to exercise any rights in respect to other lawful action, the record date shall be no more than sixty (60) days prior to the date of such other action.

**B. Failure of Board to Fix a Record Date:** If the Board, for any reason, fails to establish a record date, the following rules shall apply:

(1) **Record Date for Notice of Meetings:** The record date for determining those Members entitled to receive notice of a meeting of Members shall be the business day preceding the day on which notice is given, or, if notice is waived, the business day preceding the day on which the meeting is held.

(2) **Record Date for Voting:** The record date for determining those Members entitled to vote at a meeting of Members shall be the day of the meeting, or in the case of an adjourned meeting, the day of the adjourned meeting.

(3) **Record Date for Action by Written Ballot Without Meeting:** The record date for determining those Members entitled to vote by written ballot on proposed Association actions without a meeting, when no prior action by the Board has been taken, shall be the day on which the first written ballot is mailed or solicited. When prior action of the Board has been taken, it shall be the day on which the Board adopts the resolution relating to that action.

(4) **Record Date for Other Lawful Action:** The record date for determining those Members entitled to exercise any rights in respect to any other lawful action shall be Members at the close of business on the day on which the Board adopts the resolution relating thereto, or the 60th day prior to the date of such other action, whichever is later.

(5) **"Record Date" Means as of Close of Business:** For purposes of this subparagraph B, a person holding a membership as of the close of business on the record date shall be deemed the Member of record.

**3.9 Action without Meeting.** Any action that may be taken at any annual or special meeting of Members (except the election of Directors) may be taken without a meeting in accordance with the provisions of California Corporations Code §§ 7513 and 7516. Any form of written ballot distributed by any person to the membership of the Association shall afford the opportunity to specify a choice between approval and disapproval of each matter or group of matters to be acted upon, except it shall not be mandatory that a candidate for election to the Board be named in the written ballot. The written ballot shall provide that, where the Member specifies a choice, the vote shall be cast in accordance with that choice.

**3.10 Conduct of Meetings:** Meetings of the membership of the Association shall be conducted in accordance with a recognized system of parliamentary procedure or such parliamentary procedures as the Association may adopt. Notwithstanding any other provision of law, notice of meetings of the Members shall specify those matters the Board intends to present for action by the Members, but, except as otherwise provided by law, any proper matter may be presented at the meeting for action. Members of the Association shall have access to Association records in accordance with Article 3 (commencing with Section 8330) of Chapter 13 of Part 3 of Title 1 of the Corporations Code. Any Member shall be permitted to speak at a meeting of the Association Members; however, the Board of Directors may establish a reasonable time limit for Members to speak before a meeting of the Association Members.

#### ARTICLE IV BOARD OF DIRECTORS; SELECTION; TERM OF OFFICE

**4.1 General.** The activities and affairs of this Association shall be administered and overseen by, and the powers of the Association exercised under the direction of, a Board of Directors. The Board may delegate the management activities to any management company, to a managing agent, provided however that the activities and affairs of the Association shall be directed, overseen and managed, and the corporate powers exercised, under the ultimate direction of the Board.

**4.2 Number.** The board of Directors shall consist of five ( 5 ) Owners, or resident parents of Owners, or duly authorized officers of corporate or partnership Owners.  
The number of Directors may be changed by approval of the Members.

**4.3 Term of Office.** The Members shall elect Directors for a term of two (2) years. Terms shall be staggered so that three (3) Directors are elected one year and two (2) the following year. Unless vacated sooner, each Director shall hold office until the Director's term expires and a successor is elected.

**4.4 Compensation.** No Director shall receive compensation for any service rendered to the Association. However, any Director may be reimbursed for his actual expenses, if reasonable, that are incurred in the performance of his or her duties.

**4.5 Indemnification of Corporate Agents.** The Association shall indemnify any present or former Director, officer, employee or other agent of the Association to the fullest extent authorized under California Corporations Code §7237, or any successor statute, including, but not limited to, indemnification for claims for personal injury and/or property damage claims arising from either passive and/or active negligence, and may advance to any such person funds to pay expenses that may

be incurred in defending any action or proceeding on receipt of an undertaking by or on behalf of such person to repay such amount unless it is ultimately determined that such person was entitled to indemnification under this provision.

## ARTICLE V NOMINATION AND ELECTION OF DIRECTORS

**5.1 Nomination.** Nomination for election to the Board of Directors shall be made by a Nominating Committee. Notice to the Members of the meeting shall include the names of all those who are nominees at the time the notice is sent. Nominations may also be made from the floor at the annual meeting. The Nominating Committee shall consist of a Chairman, who shall be a member of the Board of Directors, and two (2) or more Members of the Association. The Nominating Committee shall be appointed by the Board of Directors not less than thirty (30) days prior to each annual meeting of the Members, to serve until the close of such annual meeting. The Nominating Committee shall make as many nominations for election to the Board of Directors as it shall in its discretion determine, but not less than the number of vacancies that are to be filled. All candidates shall have reasonable opportunity to communicate their qualifications to Members and to solicit votes.

**5.2 Election.** The election of the Board shall be conducted at the annual meeting of the Association. At such election the Members or their proxies may cast, in respect to each vacancy, as many votes as they are entitled to exercise under the provisions of the Declaration. The persons receiving the largest number of votes shall be elected. No cumulative voting shall be permitted. Voting for Directors shall be by secret written ballot.

## ARTICLE VI MEETINGS OF DIRECTORS

**6.1 Regular Meetings.** Regular meetings of the Board of Directors shall be held at least quarterly at such place within the Project, and at such hour as may be fixed from time to time by resolution of the Board. If a larger meeting room is required than exists within the Project, the Board shall select a room as close as possible to the Project. Should said meeting fall upon a legal holiday, then that meeting shall be held at the same time on the next day which is not a legal holiday, excluding Saturday and Sunday. Notice of the time and place of the meeting shall be posted at a prominent place within the Common Area or mailed to any Member who had requested notification of Board meetings, at the address requested by the Member. Notice may also be given, by mail or delivery of the notice to each Unit in the Project or by newsletter or similar means of communication and shall be communicated to Directors and Members not less than four (4) days prior to the meeting. Notice of any meeting need not be given to any Director who has signed a waiver of notice or a written consent to holding of the meeting. If the Common Area consists only of an easement or is otherwise unsuitable for posting of such notice, the Board shall communicate the notice of the time and place of such meeting by any means it deems appropriate.

**6.2 Special Meetings.** Special meetings of the Board of Directors shall be held when called by written notice signed by the President, Vice President or Secretary of the Association, or by any two (2) Directors. The notice shall specify the time and place of the meeting and the nature of any special business to be considered. The notice shall be given to each Director by one (1) of the following methods: (a) by personal delivery; (b) written notice by first-class mail, postage prepaid; (c) by telephone communication, either directly to the Director or to a person at the Director's office who would reasonably be expected to communicate such notice promptly to the Director; or (d) by telegram, facsimile or electronic mail. Such notice shall be posted or communicated in a manner prescribed for notice of regular meetings and shall be sent to all Directors not less than four (4) days prior to the scheduled time of the meeting. All Members shall be given notice of the time and place of a special meeting, except for an emergency meeting, at least four days prior to the meeting. Notice of the special meeting may be given by posting the notice in a prominent place or places within the Common Area, and by mail to any Member who had requested notification of Board meetings, at the address requested by the Member. Notice may also be given, by mail or delivery of the notice to each Unit in the Project or by newsletter or similar

means of communication and shall be communicated to Directors and Members not less than four (4) days prior to the meeting. Notices sent by first-class mail shall be deposited into a United States mailbox at least six (6) days before the time set for the meeting.

**6.3 Emergency Meetings.** An emergency meeting of the Board of Directors may be called by the president, or by any two Directors other than the president, if there are circumstances that could not have been reasonably foreseen which require immediate attention and possible action by the Board, and which of necessity make it impracticable to provide the notices required by section 6.1. Notice to Members of an emergency meeting is not required.

**6.4 Quorum.** A majority of the Directors then in office (but not less than two (2)) shall constitute a quorum for the transaction of business. Every act performed or decision made by a majority of the Directors present at a duly held meeting at which a quorum is present shall be regarded as the act of the Board. A meeting at which a quorum is initially present may continue to transact business, notwithstanding the withdrawal of Directors, provided at least two (2) Directors are present, if any action taken is approved by a majority of the required quorum for that meeting.

**6.5 Open Meetings.** Except as provided in sections 6.6 and 6.7, all meetings of the Board shall be open to all Members, but Members other than Directors may not participate in any discussion or deliberation unless expressly so authorized by a majority of a quorum of the Board. However, the Board shall establish a reasonable time limit for all Members of the Association to speak to the Board of Directors at any meeting of the Board of Directors, and permit any member of the Association to speak at any meeting of the Board within such time limit.

**6.6 Executive Session.** The Board may, with approval of a majority of its members present at a meeting in which a quorum for the transaction of business has been established, or, if all members of the governing body are present, by a majority vote of the members, adjourn a meeting and reconvene in executive session to discuss and vote upon litigation, matters relating to the formation of contracts with third parties, Member discipline, personnel matters, or to meet with a Member, upon the Member's request, regarding the Member's payment of assessments, as specified in Civil Code sections 1367 or 1367.1. The nature of any and all business to be considered in executive session shall first be announced in open session. Any matter discussed in executive session shall be generally noted in the minutes of the immediately following meeting that is open to the entire membership. The Board shall meet in executive session, if requested by a Member who may be subject to a fine, penalty, or other form of discipline, and the Member affected shall be entitled to attend the executive session. The Board may hold an executive session emergency meeting if circumstances require, as authorized by section 6.3.

**6.7 Telephone/Electronic Meetings.** Any Board meeting, may be held by conference telephone, electronic video screen, or other communication equipment, so long as all of the following apply:

A. Each Director participating in the meeting can communicate with all of the other Directors concurrently.

B. Each Director is provided the means of participating in all matters before the Board, including, without limitation, the capacity to propose, or to interpose an objection to a specific action to be taken by the corporation.

C. The Board adopts and implements some means of verifying both of the following:

(i) A person participating in the meeting is a Director or other person entitled to participate in the Board meeting;

(ii) All actions of, or votes by, the Board are taken or cast only by the Directors and not by persons who are not Directors.



Arrangements shall be made to enable any Member who desires to listen to the telephone/electronic meeting of the Board, to be able to do so. The minutes of the meeting shall state that those participating in the meeting were recognized to be Directors or other persons authorized to participate in the meeting. An explanation of the action taken shall be posted at a prominent place within the Common Area within three (3) days after the meeting. If the Common Area consists of an easement or is otherwise unsuitable for posting the explanation of the action taken, the Board shall communicate said explanation by any means it deems appropriate.

**6.8 Waiver of Notice.** The transactions of any meeting of the Board of Directors, however called and noticed or wherever held, shall be as valid as though taken at a meeting duly held after regular call and notice, if (a) a quorum is present, and (b) either before or after the meeting, each of the Directors not present signs a written waiver of notice, a consent to holding the meeting, or an approval of the minutes. The waiver of notice or consent need not specify the purpose of the meeting. Notice of a meeting shall also be deemed given to any Director who attends the meeting without protesting before or at its commencement about the lack of adequate notice.

**6.9 Notice of Adjourned Meeting.** Notice of the time and place of holding an adjourned meeting need not be given, unless the meeting is adjourned for more than twenty-four (24) hours, in which case personal notice of the time and place shall be given before the time of the adjourned meeting to the Directors who were not present at the time of the adjournment, and shall be posted at a prominent place within the Common Area. If the Common Area consists only of an easement or is otherwise unsuitable for posting of such notice, the Board shall communicate the notice of the time and place of such meeting by any means it deems appropriate.

**6.10 Action Without Meeting.** Any action required or permitted to be taken by the Board of Directors may be taken without a meeting (and without notice to Members provided for in section 6.2), if all members of the Board, individually or collectively, consent in writing to that action. Such action by written consent shall have the same force and effect as a unanimous vote of the Board of Directors. Such written consent or consents shall be filed with the minutes of the proceedings of the Board. An explanation of the action taken shall be posted at a prominent place or places within the Common Area within three (3) days after the written consents of all Board members have been obtained. If the Common Area consists only of an easement or is otherwise unsuitable for posting the explanation of the action taken, the Board shall communicate said explanation by any means it deems appropriate.

**6.11 Definition of Meeting.** "Meeting" includes any congregation of a majority of the members of the Board at the same time and place to hear, discuss, or deliberate upon any item of business scheduled to be heard by the Board, except those matters that may be discussed in executive session.

**6.12 Availability of Minutes:** The minutes, or minutes proposed for adoption that are marked to include draft status, or a summary of minutes of any meeting of the Board, other than an executive session, shall be available to Members within thirty (30) days of the meeting. The minutes, proposed minutes or summary shall be distributed to any Member on request and on reimbursement of the Association's costs in making that distribution.

## ARTICLE VII POWERS AND DUTIES OF THE BOARD OF DIRECTORS

**7.1 Duties.** The Board of Directors shall undertake and fulfill the following duties:

**A. Adopt Policies:** The Board shall adopt policies of the Association which shall consist of such resolutions adopted by the Board of Directors that fulfill the purposes of the Association. Said policies will serve the membership and management as the statement of the specific objectives and purposes for which the Association exists.

**B. Oversight and Review of Administration of Association Affairs.** The Board shall review and direct the officers and Managing Agent of the Association to assure that the

policies of the Association are being accomplished in a reasonable and prudent manner and that the requirements for operation of the Project as set forth in the Project Documents and the laws applicable to the Project are fulfilled to the extent reasonable and appropriate.

**C. Supervision:** The Board shall supervise all officers, agents and employees of the Association to see that their duties are properly performed;

**7.2 Powers.** The Board of Directors shall have power to:

**A. Manager:** Employ a manager or managing agent ("Managing Agent") as provided in the Declaration;

**B. Adoption of Rules:** Adopt Rules in accordance with the Declaration.

**C. Assessments, Liens and Fines:** Levy and collect Assessments and impose fines as provided in section 5.2F of the Declaration. If the Association adopts or has adopted a policy imposing any monetary penalty, including any fee, on any Association Member for a violation of the governing documents or rules of the Association, including any monetary penalty relating to the activities of a guest or invitee of a Member, the Board shall adopt and distribute to each Member, by personal delivery or first-class mail, a schedule of the monetary penalties that may be assessed for those violations, which shall be in accordance with authorization for Member discipline contained in the governing documents. The Board shall not be required to distribute any additional schedules of monetary penalties unless there are changes from the schedule that was adopted and distributed to the Members pursuant to this section.

**D. Enforcement (Notice and Hearing):** Enforce these Bylaws and/or the Declaration. When the Board is to meet to consider or impose discipline upon a Member, the Board shall notify the Member in writing, by either personal delivery or first-class mail, at least fifteen (15) days prior to the meeting. The notification shall contain, at a minimum, the date, time, and place of the meeting, the nature of the alleged violation for which a Member may be disciplined, and a statement that the Member has a right to attend and may address the Board at the meeting. The Board shall meet in executive session if requested by the Member being disciplined.

If the Board imposes discipline on a Member the Board shall provide the Member a written notification of the disciplinary action, by either personal delivery or first-class mail, within 15 days following the action. A disciplinary action shall not be effective against a Member unless the Board fulfills the requirements of this section.

Under no circumstances may the Association cause a forfeiture or abridgement of an Owner's right to the full use and enjoyment of the Owner's Unit on account of the failure of the Owner to comply with the provisions of the Declaration, Articles, Bylaws or Rules, except by judgment of a court or decision of an arbitrator, or on account of a foreclosure or a sale under power of sale for failure of the Owner to pay assessments due or levied by the Association.

**E. Contracts:** Contract for goods and/or services in accordance with section 5.2L of the Declaration;

**F. Delegation:** Delegate its authority and powers to officers or employees of the Association or to a Managing Agent employed by the Association. The Board may not delegate the authority: (i) to make expenditures for capital additions or improvements chargeable against the reserve funds; (ii) to conduct hearings concerning compliance by an Owner or his tenant, lessee, guest or invitee with the Declaration or Rules and regulations promulgated by the Board; (iii) to make a decision to levy monetary fines, impose special Assessments against individual Units, temporarily suspend an Owner's rights as a Member of the Association or otherwise impose discipline following any such hearing; (iv) to make a decision to levy annual or special Assessments; or (v) to make a decision to bring suit, record a claim of lien, or institute foreclosure proceedings for default in payment of Assessments. Any delegation

shall be revocable by the Board at any time. The members of the Board, individually or collectively, shall not be liable for any omission or improper exercise by the Managing Agent of any such duty, power or function so delegated by written instrument executed by a majority of the Board.

**G. Appointment of Trustee:** Appoint a trustee to enforce assessment liens by power of sale as provided in the Declaration and in California Civil Code § 1367(b).

**H. Other Powers:** In addition to any other power contained herein, the Association may exercise the powers granted to a nonprofit mutual benefit corporation as enumerated in California Corporations Code § 7140.

## ARTICLE VIII ASSOCIATION DUTIES AND RESPONSIBILITIES

**8.1 Association Duties:** The Association shall, as provided in these Bylaws or as the Board may otherwise direct, through its Managing Agent, undertake the following duties and responsibilities:

**A. Maintenance:** Perform the maintenance described in section 5.1A of the Declaration;

**B. Insurance:** Maintain insurance as required by section 8.1 of the Declaration. The Association shall, upon issuance or renewal of insurance, but not less than annually, notify the Members as to the amount and type of insurance carried by the Association, and it shall accompany this notification with statements (required under Civil Code § 1365(e)) to the effect that the Association is or is not insured to the levels specified by Civil Code § 1365.9, and that if the Association is not so insured that Owners may be individually liable for the entire amount of a judgment, and, if the Association is insured to the levels specified in the section, then the Owners may be individually liable only for their proportional share of Assessments levied to pay the amount of any judgment which exceeds the limits of the association's insurance. The Association shall not levy any Assessment against the Members to pay the amount of any judgment against the Association without a vote approving such Assessment or written consent of a majority of the Members.

The Association shall prepare and distribute to its Members the summaries of the Association's insurance policies as required by the Civil Code § 1365(e), pursuant to Section 12.1(5).

**C. Discharge of Liens:** Discharge by payment, if necessary, any lien against the Common Area and assess the cost thereof to the Member or Members responsible for the existence of the lien (after notice and hearing as required by these Bylaws);

**D. Assessments:** Fix, levy, collect and enforce Assessments as set forth in Article IV of the Declaration;

**E. Expenses and Obligations:** Pay all expenses and obligations incurred by the Association in the conduct of its business including, without limitation, all licenses, taxes, or governmental charges levied or imposed against the property of the Association;

**F. Enforcement:** Enforce these Bylaws and the Declaration;

**G. Records:** Cause to be kept a complete record of all its acts and affairs and to present a statement thereof to the Members at the annual meeting of the Members, or at any special meeting when such statement is requested in writing by one-fourth (1/4) of the Class A Members; keep adequate and correct books and records of account, minutes of proceedings of its Members, Board and committees, and a record of its Members giving their names and addresses and classes of membership;

H. **Contracts:** Contract for goods and/or services in accordance with section 5.2L of the Declaration;

I. **Financial Requirements.** Comply with the Financial Requirements set forth in Article XII of these Bylaws.

## ARTICLE IX OFFICERS AND THEIR DUTIES

9.1 **Enumeration of Officers.** The officers of this Association shall be a President and Vice President, who shall at all times be members of the Board of Directors, a Secretary, and a Chief Financial Officer, and such other officers as the Board may from time to time by resolution create.

9.2 **Election of Officers.** The election of officers shall take place at the first meeting of the Board of Directors following each annual meeting of the Members.

9.3 **Term.** Each officer of this Association shall be elected annually by the Board and each shall hold office for one (1) year unless he or she shall sooner resign, or is removed, or is found by the Board to be disqualified to serve.

9.4 **Special Appointments.** The Board may elect such other officers as the affairs of the Association may require, each of whom shall hold office for such period, have such authority, and perform such duties as the Board may, from time to time, determine.

9.5 **Resignation and Removal.** Any officer may be removed from office (but not from the Board, if the officer is also a Board member) by the Board with or without cause. Any officer may resign at any time by giving written notice to the Board, the President or the Secretary. Such resignation shall take effect on the date of receipt of such notice or at any later time specified therein, and unless otherwise specified therein, the acceptance of such resignation shall not be necessary to make it effective.

9.6 **Vacancies.** A vacancy in any office may be filled by appointment by the Board. The officer appointed to such vacancy shall serve for the remainder of the term of the officer he replaces.

9.7 **Duties.** The duties of the officers are as follows:

A. **President.** The President shall preside at all meetings of the Board of Directors; shall see that orders and resolutions of the Board are carried out; shall sign all leases, mortgages, deeds and other written instruments and shall sign all promissory notes. The President shall have the general powers and duties of management usually vested in the office of the President of a California nonprofit mutual benefit corporation, and shall have such powers and duties as may be prescribed by the Board or by these Bylaws;

B. **Vice President.** The Vice President shall act in the place and stead of the President in the event of his absence, inability or refusal to act, and shall exercise and discharge such other duties as may be required by the Board;

C. **Secretary.** The Secretary shall record the votes and keep the minutes of all meetings and proceedings of the Board and of the Members; serve notice of meetings of the Board and of the Members; keep appropriate current records showing the Members of the Association together with the addresses, and shall perform such other duties as required by the Board;

D. **Chief Financial Officer (Treasurer).** The Chief Financial Officer shall receive and deposit in appropriate bank accounts all monies of the Association and shall disburse such funds as directed by resolution of the Board of Directors; shall sign all promissory notes of the

Association; shall keep proper books of account; shall prepare and shall distribute budgets and financial statements to each Member as required under these Bylaws, and by applicable laws.

## ARTICLE X COMMITTEES

**10.1 Nominating Committee.** An Architectural Control Committee may be appointed as provided in the Declaration and a Nominating Committee, as provided in section 5.1 of these Bylaws.

**10.2 Other Committees.** In addition, the Board of Directors shall appoint other committees as deemed appropriate in carrying out its purpose.

**10.3 Limitations on Committees.** No committee, regardless of Board resolution, may: (a) take any final action on matters which, under the Nonprofit Corporation Law of California, also requires Members' approval; (b) fill vacancies on the Board of Directors or in any committee; (c) amend or repeal Bylaws or adopt new Bylaws; (d) amend or repeal any resolution of the Board of Directors; (e) appoint any other committees of the Board of Directors or the members of those committees; (f) approve any transaction to which the Association is a party and in which one (1) or more Directors have a material financial interest.

**10.4 Purpose of Committees.** The purpose of all committees shall be to assist the Board of Directors in the development of policies and to assist in the oversight and assessment of the Association policies. No committee shall be assigned, delegated or chartered in any manner which would authorize them to take final action in the name of the Association. No committee, officer of a committee or member of the committee shall act take an action that is assigned to the Office of the President or other Officers of the Association. All committees shall report to the Board and shall serve at the pleasure of the Board. Committees of the Board shall not have authority to direct contractors, agents or Officers of the Association.

## ARTICLE XI BOOKS AND RECORDS

**11.1 Inspection by Members.** The membership register (including names, mailing addresses, telephone numbers and voting rights), accounting books and records, and minutes of meetings of the Members, of the Board (and including drafts and summaries), and of committees shall be made available for inspection and copying by any Member of the Association, or by his duly appointed representative, at any reasonable time and for a purpose reasonably related to his interest as a Member, at the office of the Association or at such other place within the Project as the Board shall prescribe. Board minutes (or proposed minutes or draft or summary thereof), other than for an executive session, shall be available to Members within thirty (30) days of the meeting, and shall be distributed to any Member upon request and upon reimbursement of the costs in making that distribution.

**11.2 Rules for Inspection.** The Board shall establish reasonable rules with respect to:

- A. Notice to be given to the custodian of the records by the Member desiring to make the inspection;
- B. Hours and days of the week when such an inspection may be made;
- C. Payment of the cost of reproducing copies of documents requested by a Member.

**11.3 Inspection by Directors.** Every Director shall have the absolute right at any reasonable time to inspect all books, records and documents of the Association and the physical

properties owned or controlled by the Association. The right of inspection by a Director includes the right to make extracts and copies of documents, at the expense of the Association.

**11.4 Documents Provided by Association:** Upon written request, the Association, through the Managing Agent, or if there is no Managing Agent, through the Secretary, shall, within ten (10) days of the mailing or delivery of such request, provide the Owner of a Unit with a copy of the governing documents of the Project, a copy of the most recent budget and statements of the Association distributed pursuant to section 12.1, together with a true statement in writing from an authorized representative of the Association as to the amount of the Association's current regular and special Assessments and fees, as well as any Assessments levied upon the Owner's interest which are unpaid on the date of the statement, including late charges, interest, and costs of collection which, as of the date of the statement, are or may be made a lien upon the Owner's Condominium. The Board may impose a fee for providing the foregoing which may not exceed the reasonable cost to prepare and reproduce the requested documents.

## ARTICLE XII FINANCIAL AND REPORTING REQUIREMENTS

**12.1 Budgets, Financial Statements and Reports:** The Association shall cause to be prepared and distributed budgets, financial statements and reports to each Member as follows:

(1) a pro forma operating budget in accordance with Civil Code section 1365 for each fiscal year shall be distributed not less than thirty (30) nor more than ninety (90) days before the beginning of the fiscal year consisting of at least the following:

(a) Estimated revenue and expenses on an accrual basis;

(b) A summary of the Association's reserves based upon the most recent review or study conducted pursuant to section 12.2, based only on assets held in cash or cash equivalents which shall be printed in bold type and include all of the following:

(i) The current estimated replacement cost, estimated remaining life, and estimated useful life of each Major Component;

(ii) As of the end of the fiscal year for which the study is prepared:

(A) The current estimate of the amount of cash reserves necessary to repair, replace, restore, or maintain the Major Components;

(B) The current amount of accumulated cash reserves actually set aside to repair, replace, restore, or maintain Major Components;

(C) If applicable, the amount of funds received from either a compensatory damage award or settlement to the Association from any person or entity for injuries to property, real or personal, arising out of any construction or design defects, and the expenditure or disposition of funds, including the amounts expended for the direct and indirect costs of repair of construction or design defects. These amounts shall be reported at the end of the fiscal year for which the study is prepared as separate line items under cash reserves pursuant to Clause (B). In lieu of complying with this requirement, the Association may include in the review of its financial statement pursuant to paragraph 2(d), below, a statement containing all of the foregoing information;

(D) The percentage that accumulated cash reserves actually set aside is of the current estimate of cash reserves necessary;

(c) A statement as to [1] whether the Board has determined or anticipates that the levy of one or more special Assessments will be required to repair, replace, or restore any Major Component or to provide adequate reserves therefor [If so, the statement shall also set out the estimated amount, commencement date and duration of the Special Assessment]; and [2] the mechanism or mechanisms by the Board will fund reserves to repair or replace Major Components, including Assessments, borrowing, use of other assets, deferral of selected replacement or repairs, or alternative mechanisms;

(d) A general statement setting forth the procedures used in the calculation and establishment of those reserves to defray the future repair, replacement or additions to those Major Components that the Association is obligated to maintain. The report shall include, but shall not be limited to, reserve calculations made using the formula describe in paragraph (4) of subdivision (b) of Civil Code section 1365.2.5.

In lieu of the distribution of the pro forma operating budget, the Board may elect to distribute a summary of the items described hereinabove, to all the Members, with written notice that the budget is available at the business office of the Association or at another suitable location within the boundaries of the development and that copies will be provided upon request and at the expense of the Association. Members shall be notified in writing at the time that the pro forma budget is distributed, or at the time of any general mailing to the entire membership, of their right to have copies of the minutes of meetings, and how and where those minutes may be obtained. If any Member requests a copy of the pro forma operating budget, including the items referred to above, to be mailed to the Member, the Association shall provide the copy to the Member by first-class United States mail at the expense of the Association and delivered within five (5) days. The written notice that is distributed to each of the Association Members shall be in at least 10-point bold type on the front page of the summary of the statement;

(2) A report consisting of the following shall be distributed within one hundred twenty (120) days after the close of the fiscal year: (a) a balance sheet as of the end of the fiscal year; (b) an operating (income) statement for the fiscal year; (c) a statement of changes in financial position for the fiscal year; (d) for any fiscal year in which the gross income to the Association exceeds Seventy-Five Thousand Dollars (\$75,000), a copy of a review of the financial statement of the Association prepared in accordance with generally accepted accounting principles by a licensee of the California State Board of Accountancy; (e) any information required to be reported under § 8322 of the California Corporations Code;

(3) if the report referred to in (2) above is not prepared by an independent accountant, it shall be accompanied by the certificate of an authorized officer of the Association that the statement was prepared from the books and records of the Association without independent audit or review;

(4) A statement describing the Association's policies and practices in enforcing lien rights, foreclosures, or other legal remedies for default in payment of its Assessments against its Members, and a statement of the place where the names and addresses of the current Members are located shall be distributed annually to the Members, and to any First Lender who has requested a copy, distributed annually not less than thirty (30) nor more than ninety (90) days before the beginning of the fiscal year. The notice shall be printed in at least 12-point type.

(5) A summary of the Association's insurance policies as set forth in and required by Civil Code § 1365(e)(1) shall be distributed to the Members annually not less than thirty (30) nor more than ninety (90) days before the beginning of the fiscal year. The summary shall contain in at least 10-point bold face type the following statement:

This summary of the Association's policies of insurance provides only certain information as required by subdivision (e) of §1365 of the Civil Code and should not be considered a substitute for the complete policy terms and conditions contained in the actual policies of insurance. Any Association

member, upon request and reasonable notice, may review the Association's insurance policies and, upon request and payment of reasonable duplication charges, obtain copies of those policies. Although the Association maintains the policies of insurance specified in this summary, the Association's policies of insurance may not cover your property, including personal property, or real property improvements to or around your dwelling, or personal injuries or other losses that occur within or around your dwelling. Even if a loss is covered, you may nevertheless be responsible for paying all or a portion of any deductible that applies. Association members should consult with their individual insurance broker or agent for appropriate additional coverage.

(6) The Board shall comply with the requirements of California Civil Code § 1369.590 by providing Members of the Association annually with a summary of the provisions Article 2 (commencing with Civil Code section 1369.510) of Chapter 7 of Title 6 (Division 2, Part 4) of the California Civil Code, including the following language: "Failure by any Member of the Association to comply with the alternative dispute resolution requirements of Section 1369.520 of the Civil Code may result in the loss of your rights to sue the Association or another Member of the Association regarding enforcement of the governing documents or the applicable law."

(7) The Board shall comply with the requirements of California Civil Code § 1365.1 by distributing a written notice as described in subdivision (b) of Civil Code § 1365.1 entitled "Notice Assessments and Foreclosure" to each Member of the Association during the 60-day period immediately preceding the beginning of the Association's fiscal year. The notice is to be printed in at least 12-point type.

(8) The Board shall annually provide the members with notice of any requirements for Association approval of physical changes to Units and Common Areas. The notice shall describe the types of changes that require Association approval and shall include a copy of the procedure used to review and approve or disapprove a proposed change.

**12.2 Reserve Studies:** At least every three years the Board shall cause a study of the reserve account requirements of the Project to be conducted, including a reasonably competent and diligent visual inspection of the accessible areas of the Major Components which the Association is obligated to repair, replace, restore, or maintain, if the current replacement value of said Major Components is equal to or greater than one-half of the gross budget of the Association, excluding the Association's reserve account for that period. The Board shall review this study, or cause it to be reviewed annually and shall consider and implement necessary adjustments to the Board's analysis of the reserve account requirements as a result of that review.

The study required by this section shall at a minimum include:

(1) Identification of the Major Components which the Association is obligated to repair, replace or restore, or maintain which, as of the date of the study, have a remaining useful life of less than thirty (30) years;

(2) Identification of the probable remaining useful life of the components identified in paragraph (1) as of the date of the study;

(3) An estimate of the cost of repair, replacement, restoration, or maintenance of each Major Component identified in paragraph (1) during and at the end of its useful life; and

(4) An estimate of the total annual contribution necessary to defray the cost to repair, replace, restore, or maintain each Major Component during and at the end of its useful life, after subtracting total reserve funds as of the date of the study.

As used in this section 12.2, the definition of reserve account shall mean both: (a) monies that the Association's Board of Directors has identified for use to defray the future repair or replacement



of, or additions to, those Major Components which the Association is obligated to maintain; and (b) funds received but not expended or disposed from either a compensatory damage award or settlement to the Association from any person or entity for injuries to property, real or personal, arising from any construction or design defects, which funds shall be separately itemized from funds described as the items in (a) above.

As used in this section, "reserve account requirements" means the estimated funds which the Board has determined are required to be available at a specified point in time to repair, replace, or restore those Major Components which the Association is obligated to maintain.

**12.3 Reserve Account Fund Management:** The Board shall not expend funds designated as reserve funds for any purpose other than the repair, restoration, replacement, or maintenance of Major Components which the Association is obligated to repair, restore, replace, or maintain ("Association Major Components") and for which the reserve fund was established, or litigation involving Association Major Components. However, the Board may authorize the temporary transfer of moneys from a reserve fund to the Association's general operating fund to meet short-term cash-flow requirements or other expenses, if the Board has provided notice of the intent to consider the transfer in a notice of meeting which shall be provided as specified in Civil Code section 1363.05, which notice shall include the reasons the transfer is needed, some options for repayment, and whether a Special Assessment may be considered. If the Board authorizes the transfer, the Board shall issue a written finding recorded in the minutes of the Board explaining the reason that the transfer is needed, and describing when and how the money will be repaid to the reserve fund. The transferred funds shall be restored to the reserve fund within one (1) year of the date of the initial transfer, except that the Board may, after giving the same notice required for considering a transfer, and, upon making a finding supported by documentation that a delay would be in the best interests of the Project, delay the restoration until the time which the Board reasonably determines to be necessary. The Board shall exercise prudent fiscal management in maintaining the integrity of the reserve account, and shall, if necessary, levy a special Assessment to recover the full amount of the expended funds within the time limits required by this section. This special Assessment is subject to the limitation imposed by section 4.4 of the Declaration. The Board may, at its discretion, extend the date the payment on the special Assessment is due. Any extension shall not prevent the Board from pursuing any legal remedy to enforce the collection of an unpaid special Assessment. When the decision is made to use reserve funds or to temporarily transfer money from the reserve fund to pay for litigation, the Association shall notify the Members of the Association of that decision in the next available mailing to all Members pursuant to Section 5016 of the Corporations Code, and of the availability of any accounting of those expenses. Unless the Project Documents impose more stringent standards, the Association shall make an accounting of expenses related to the litigation on at least a quarterly basis. The accounting shall be made available for inspection by Members of the Association at the Association's office.

**12.4 Reserve Account Withdrawal Restrictions:** At least two (2) signatures shall be required for the withdrawal of monies from the Association's reserve accounts, required signatures shall be those of members of the Board or one (1) member of the Board and one (1) officer who is not a member of the Board.

**12.5 Review of Financial Records:** The Board shall review on at least a quarterly basis a current reconciliation of the Association's operating and reserve accounts, the current year's actual reserve revenues and expenses compared to the current year's budget, and an income and expense statement for the Association's operating and reserve accounts. In addition, the Board shall review the latest account statements prepared by the financial institutions where the Association has its operating and reserve accounts. For purposes herein, "reserve accounts" shall mean monies that the Association's Board has identified for use to defray the future repair or replacement of, or additions to, those Major Components which the Association is obligated to maintain.

**12.6 Future Changes in Financial Records and Reserve Account Requirements:** The provisions of subsections 12.1 - 12.5 incorporate the statutory requirements of California Civil Code

§ 1365.5. If said § 1365.5 is amended in any manner, said sections shall be amended in the same manner without the necessity of amending these Bylaws.

**ARTICLE XIII  
MISCELLANEOUS**

**13.1 Amendments.** These Bylaws may be amended, only by the affirmative vote (in person or by proxy) or written consent of Members representing a majority of a quorum of the Association. However, the percentage of voting power necessary to amend a specific clause or provision shall not be less than the prescribed percentage of affirmative votes required for action to be taken under that clause.

**13.2 Conflicts.** In the case of any conflict between the Articles and the Bylaws, the Articles shall control; and in the case of any conflict between the Declaration and these Bylaws, the Declaration shall control.

**13.3 Fiscal Year.** Unless the Board directs otherwise, the fiscal year of the Association shall begin on the first day of October and end September thirty (30) of every year.

**CERTIFICATE**

I, the undersigned, the duly elected and acting Secretary of MENLO COMMONS ASSOCIATION, a California nonprofit mutual benefit corporation, do hereby certify that the foregoing Bylaws were adopted as the Amended Bylaws of the Association and have been approved by the written consent of not less than fifty-one percent (51%) of the condominium owners.

This Certificate is executed under penalty of perjury on 10/11/2005, in Menlo Park, California.

Dated: 10/11/2005

KAY MARTIN  
Secretary (print)

Kay Martin  
Signature

2007-072889

02:09pm 05/10/07 A3 Fee: 13.00

Count of pages 3

Recorded in Official Records

County of San Mateo

Warren Slocum

Assessor-County Clerk-Recorder

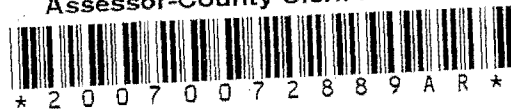

RECORDED AT THE REQUEST OF  
AND WHEN RECORDED RETURN TO:

KEVIN D. FREDERICK, ESQ.  
702 MARSHALL STREET, SUITE 620  
REDWOOD CITY, CA 94063  
(650) 365-9800

FIRST AMENDMENT TO  
AMENDED AND RESTATED DECLARATION OF  
MENLO COMMONS ASSOCIATION

THIS FIRST AMENDMENT TO THE AMENDED AND RESTATED  
DECLARATION is made on February 12, 2007, by the MENLO COMMONS  
ASSOCIATION, a California nonprofit corporation (hereinafter "Association").

RECITALS

A. On March 11, 1977, a DECLARATION OF COVENANTS, CONDITIONS  
AND RESTRICTIONS was recorded in the Office of the Recorder of San Mateo County, at  
Book 7405, page 331 for the Association and its members, applicable to the real property located  
in the City of Menlo Park, County of San Mateo, State of California, more particularly described  
in that certain Map entitled "Parcel Map of A Condominium Project", which map was filed for  
record on September 30, 1976, in Volume 33 of Parcel Maps, at Page 27, San Mateo County  
Records.

B. On November 6, 1987, an Amended and Restated Declaration of Covenants,  
Conditions and Restrictions was recorded in the Office of the Recorder of San Mateo County, as  
Document No. 87-169708.

C. On December 27, 1994, an Amendment to the Declaration of Covenants,  
Conditions and Restrictions was recorded in the Office of the Recorder of San Mateo County, as  
Document No. 94-192743.

D. On October 11, 2005, an Amended and Restated Declaration was recorded in the Office of the Recorder of San Mateo County, as Document No. 2005-177083.

E. Association now desires to make a First Amendment to the Amended and Restated Declaration pursuant to Article 9.4 of the Declaration as hereinafter provided.

Wherefore, the Amended and Restated Declaration is amended as follows.

1. Article 7.9F(2)(c) is amended to read as follows:

(c) "Quota" for purposes of this section 7.9 means the number of leased/rented Units at any point in time shall not be more than fifteen (15) out of a total one hundred twenty-two units. The Owners currently renting or leasing their Unit over and above the allowed fifteen (15) are permitted to continue renting or leasing their Unit until the sale of said Unit. Thereupon, the previously leased or rented Units, over the fifteen (15) Units allowed that have been sold shall not be leased or rented again.

2. Article 8.1(7) is amended to read as follows:

**8.1 Insurance:** The Association shall obtain and maintain the following insurance:

(7) earthquake insurance to the extent required by law, and if not required by law, then to the extent available at commercially reasonable rates in the opinion of the Board. For the purposes of earthquake insurance only, the following items of property contained within the 122 Units shall be the responsibility of the insured (Menlo Commons Homeowners Association) subject to the limits and deductible provisions of the earthquake policy:

(1) Fixtures, all walls, improvements and alterations that are a part of the building or structure.

(2) Appliances such as those used for refrigerating, ventilating, cooking,

dishwashing, laundering, security or housekeeping.

The earthquake insurance policy's deductible provisions, when applicable to an individual Unit, shall be the responsibility of the Unit Owner.

IN WITNESS WHEREOF, this First Amendment to the Amended and Restated Declaration is executed by the President of the Association.

Executed at Menlo Park California, on the 26 day of April, 2007.

MENLO COMMONS ASSOCIATION

BY: Sandra W. Kalt  
President

State of California )  
                                  )ss.  
County of San Mateo )

On April 26<sup>th</sup>, 2007, before me, Mayra I Hermosillo, a Notary Public, personally appeared, SANDRA W. KALT personally known to me or proved to me on the basis of satisfactory evidence to be the person whose name is subscribed to the within instrument and acknowledged to me that he/she executed the same in his/her authorized capacity, and that by his/her signature on the instrument the person, or the entity upon behalf of which the person acted, executed the instrument.

WITNESS my hand and official seal.

Mayra I Hermosillo

